



Member state
Czech Republic

OIML Certificate No.
R76/2006-CZ-16.04

OIML BASIC CERTIFICATE OF CONFORMITY

Issuing Authority

Name: Czech Metrology Institute
Address: Okružní 31,
638 00 Brno, CZ
Person responsible: Jan Kalandra

Applicant

Name: **RADWAG WAGI ELEKTRONICZNE Witold Lewandowski**
Address: **ul. Bracka 28**
26-600 Radom
Poland

Manufacturer of the certified type

Name: **RADWAG WAGI ELEKTRONICZNE Witold Lewandowski**
Address: **ul. Bracka 28**
26-600 Radom
Poland

Identification of the certified type

Non-automatic weighing instrument
Type: AS xxx.X2.yyy

Further characteristics see pages 3 - 8.

This certificate attests the conformity of above identified type (represented by the sample (s) identified in the OIML Basic Type Evaluation Report) with the requirements of the following Recommendation of the International Organization of Legal Metrology (OIML):

OIML R 76, edition 2006 for accuracy class **I**

Member state
Czech Republic

OIML Certificate No.
R76/2006-CZ-16.04

This certificate relates only to the metrological and technical characteristics of the type of measuring instrument covered by the relevant OIML Recommendation identified above.

This certificate does not bestow any form of legal international approval.

The conformity was established by the results of tests and examinations provided in the associated OIML Basic Type Evaluation Report(s):

No. 6012-PT-CH020-15 from 14 September 2015 having 32 pages.

No. 8551-PT-E0175-15 from 18 August 2015 having 17 pages.

Certificate history:

Issue no.	Date	Description of the modification



The OIML Issuing Authority
Pavel Klenovský

12 August 2016

Important note: Apart from the mention of the Certificate's reference number and the name of the OIML Member State in which the Certificate is issued, partial quotation of the Certificate and of the associated OIML Basic Type Evaluation Report(s) is not permitted, although either may be reproduced in full.

Instrument description

Balance AS xxx.X2.yyy series is a model operating on basis of electromagnetic compensation of weighed load. This series features a measuring range to 310g and measuring resolution 0,01mg or 0,1mg or 1mg respectively. High resolution, repeatability and measuring range of the AS xxx.X2.yyy series is maintained by highly stable electronic and mechanical components, as well as application of automatic internal adjustment system. Balance has full graphic display, plastic cover, stainless steel plate, weighing chamber, automatic internal adjustment system. The type designation is AS xxx.X2.yyy. Symbol xxx stands for Max (g) and symbol yyy stands for special purpose of balance e.g. jewelry balance – CT.

Description of the instrument:

Description	Drawing number
Schedule of balance working	AS.X2-01-001 sheet 1/4; sheet 2/4; sheet 3/4
Side view	Drawing 1
Localization of nominal label and data plate	Drawing 2
Display	Drawing 3
View with open case	AS X2-02-001

Metrological characteristic

Type	AS 82/220.X2	AS 62.X2	AS 160.X2	AS 220.X2	AS 310.X2
Maximum capacity	220 g	62 g	160 g	220 g	310 g
Minimum capacity	1 mg		10 mg		
Resolution (d)	0,01/0,1 mg	0,01 mg	0,1 mg		
Verification interval (e)	1 mg				
Tare range (T)	- 220 g	- 62 g	- 160 g	- 220 g	- 310 g
Working temperature	+10 °C / +40 °C				
Supply	100 V – 240 VAC, 50-60 Hz / 12 – 16 VDC				
Accuracy class	I				

The above table is an example of some models within the approved range.

Characteristics and devices

The instruments must be equipped with a level indicator with a sensitivity of at least 2 mm for a tilt of 2/1000.

Devices:

- Zero indicator
- Stability indicator
- Automatic span adjustment with internal calibration mass
- Checking the display
- Initial zero-setting
- Zero-tracking
- Data Storage Device (Alibi Memory)
- Service menu via switch on the main board
- Printer
- Add display

- USB
- Ethernet
- Weighing in carat units*)

*) For instruments that are able to display in both units if the Max, Min and e values are on a label then they must be marked on the instrument in both units. If the values are shown on a display, then they can be switched.

Data Storage Device (Alibi Memory)

Models of AS xxx.X2.yyy balances are equipped with a Data Storage Device (Alibi memory) acting as a long term memory. It automatically saves weighing results according to principles of WELMEC 2.5 in the internal flash memory. A program operates as a simple embedded software without any operating system which prevents from running any external application. The program allows to upload the content of the alibi memory to an external flash drive for archival purposes. The program does not allow to download the alibi memory content to the balance. Each measurement is identified by the following data:

- Measurement date
- Measurement time
- Measurement value (mass) - (display unit)
- Measurement value (mass) - (calibration unit)
- Tare value
- Operator (if logged on)
- Product (if chosen)

The memory size allows to save 500 000 weighing results. After the full capacity is reached the single records of the oldest data are overwritten by new data. Single records and the whole database are protected by checksums. Any corruption of data prevents them from viewing or printing.

Interfaces

Interfaces used must comply with 5.3.6 of OIML R76 (2016). Following interface is used: RS 232, USB 2.0, Ethernet 10/100Mbit. Optionally the balances may be equipped in wireless interfaces WiFi.

Software

Instruments are equipped with embedded software that is used in a fixed hardware and software environment and cannot be modified or uploaded via any interface or by other means after securing and/or verification. Software identification by its version number is accessible after pressing ON/OFF key on the overlay.

The valid software version is: 2.2.0.

Connectable devices

For applications not subject to mandatory verification, any peripheral devices may be connected.

Drawing 1 - Side view



Drawing 2 - Main label position and legalization sign

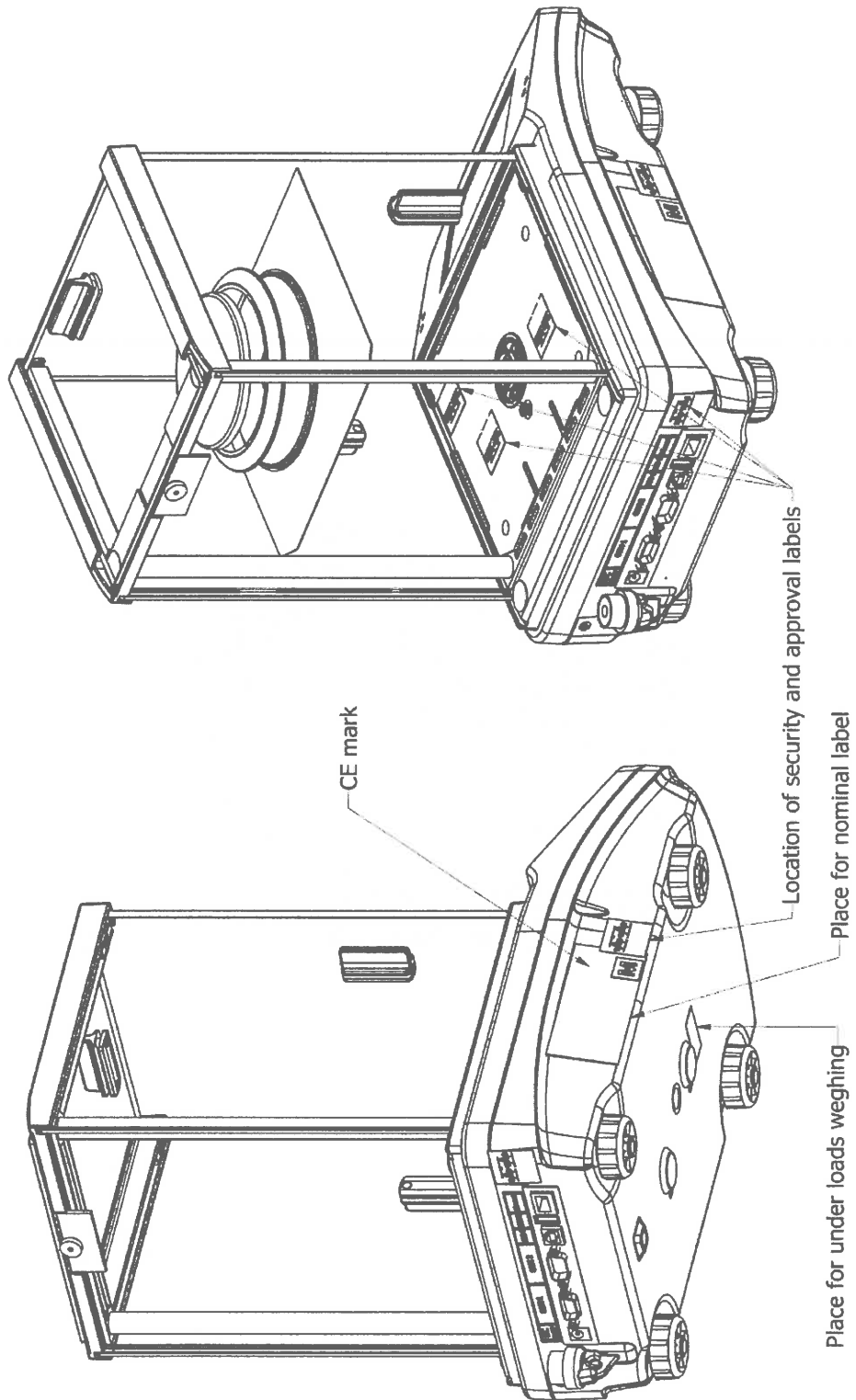

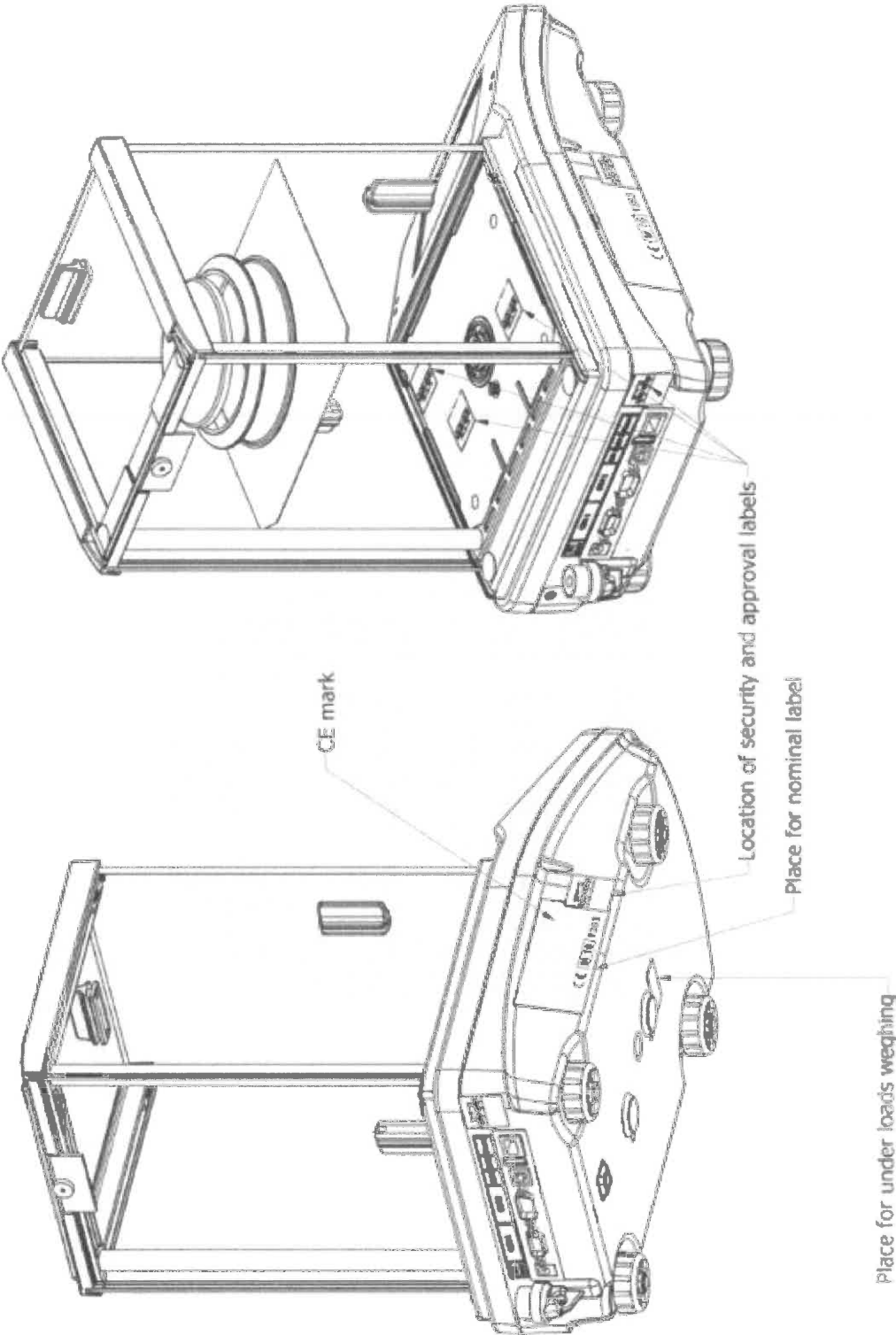

Drawing 3 - Overlay with display:

