



**OIML Member State**  
Czech Republic

**OIML Certificate No.**  
R137/2012-A-CZ1-24.03

**OIML CERTIFICATE ISSUED UNDER SCHEME A**

**OIML Issuing Authority**

Name: Czech Metrology Institute  
Address: Okružní 31,  
638 00 Brno  
Czech Republic

Person responsible: Jan Kalandra

**Applicant**

Name: Hangzhou Zexing Metering Co., Ltd  
Address: 2031, Building 2, No. 1418-5 Moganshan Road, Shangcheng Industrial Zone  
310011 Hangzhou City  
Zhejiang Province  
China

**Manufacturer**

Name: Hangzhou Zexing Metering Co., Ltd  
Address: 2031, Building 2, No. 1418-5 Moganshan Road, Shangcheng Industrial Zone  
310011 Hangzhou City  
Zhejiang Province  
China

**Identification of the certified type** *(the detailed characteristics will be defined in the additional pages)*

diaphragm gas meter  
type: HXG110 (G4, G2.5, G1.6)

**Designation of the module** *(if applicable)*

---

This OIML Certificate attests the conformity of the above identified type (represented by the sample(s) identified in the OIML type evaluation report) with the requirements of the following Recommendation of the International Organization of Legal Metrology (OIML):

OIML R137

Edition (year): 2012, Including Amendment 2014

For accuracy class (if applicable): 1.5



This OIML Certificate relates only to metrological and technical characteristics of the type of measuring instrument covered by the relevant OIML Recommendation identified above.

This OIML Certificate does not bestow any form of legal international approval.

The conformity was established by the results of tests and examinations provided in the associated OIML type evaluation report:

- No. 0511-ER-P089-24 dated 17.9.2024 that includes 17 pages.
- Test Report No. 5012-PT-A0008-24 dated 27.5.2024 that includes 21 pages.

The technical documentation relating to the identified type is contained in documentation file:  
0511-UL-P089-24

#### OIML Certificate History

Revision No.	Date	Description of the modification
-	9 October 2024	Issuing Certificate

Identification, signature and stamp

#### The OIML Issuing Authority

RNDr. Pavel Klenovský  
Head of Certification Body

Date: 9 October 2024



*Important note:* Apart from the mention of the Certificate's reference number and the name of the OIML Member State in which the Certificate is issued, partial quotation of the Certificate and of the associated OIML type evaluation report(s) is not permitted, although either may be reproduced in full.

1 General information concerning the type

Information, indicated on the instrument	
Manufacturer's trade mark	---
Type designation	HXG110 (G4, G2.5, G1.6)
Accuracy class	1.5
Cyclic volume (if applicable)	1.2 dm <sup>3</sup>
Minimum pressure $p_{min}$	0 bar(g)
Maximum pressure $p_{max}$	0.5 bar(g)
Ambient temperature range	(-25 ... +55) °C
Gas temperature range	(-25 ... +55) °C
Base pressure (if applicable)	Not applicable
Base temperature (if applicable)	Not applicable
$t_{sp}$ (if applicable)	Not applicable
Electrical power	Not applicable
Identification of software	Not applicable

Example of the label:

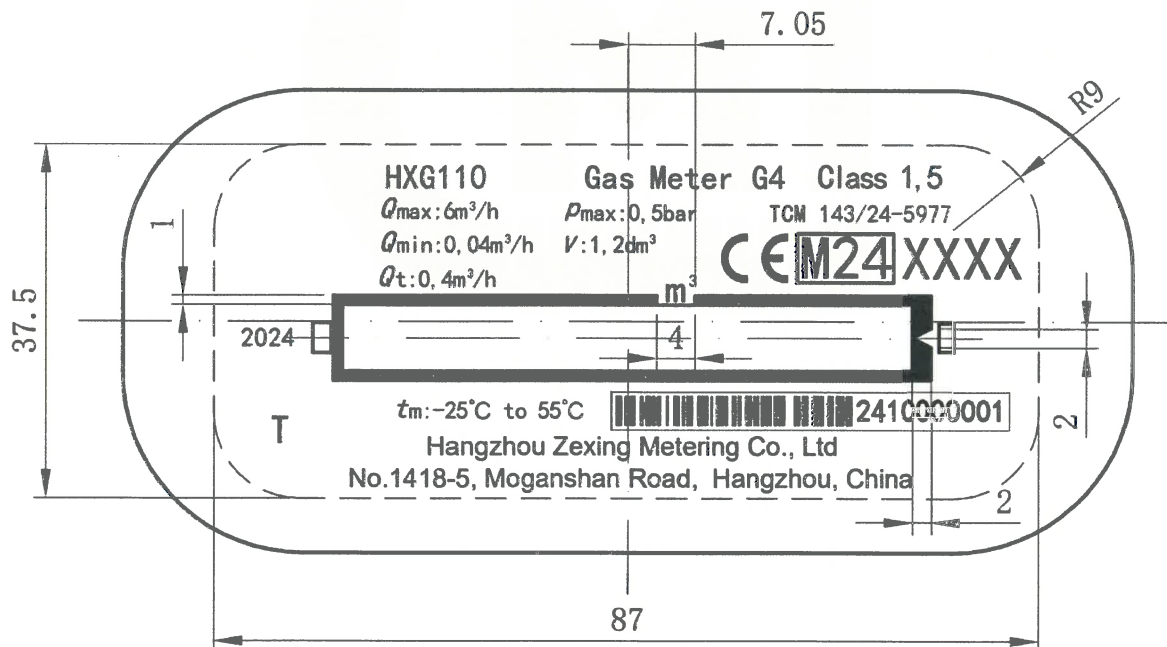

Photos of the constructions:



## 2 Additional information concerning the type

Size G	$Q_{max}$ (m <sup>3</sup> /h)	$Q_t$ (m <sup>3</sup> /h)	$Q_{min}$ (m <sup>3</sup> /h)	Cyclic volume $V$ (dm <sup>3</sup> )	Maximum permissible pressure loss $\Delta P$ in $Q_{max}$ (Pa)	$P_{max}$ (kPa)
G4	6.0	0.6	0.04	1.2	200	50
G2.5	4.0	0.4	0.025	1.2	200	50
G1.6	2.5	0.25	0.016	1.2	200	50

The gas meter can be produced with the distance between connections (male threads):  
130 mm, 110 mm

The male threads used in gas meters HXG110 (G4, G2.5, G1.6):  
M30×2, G1¼, 3/4" BS746, 1"BS746, M34×1.5

The gas meter does not contain any electronic components.

*Dimensions of diaphragm gas meters HXG110 (G4, G2.5, G1.6):*

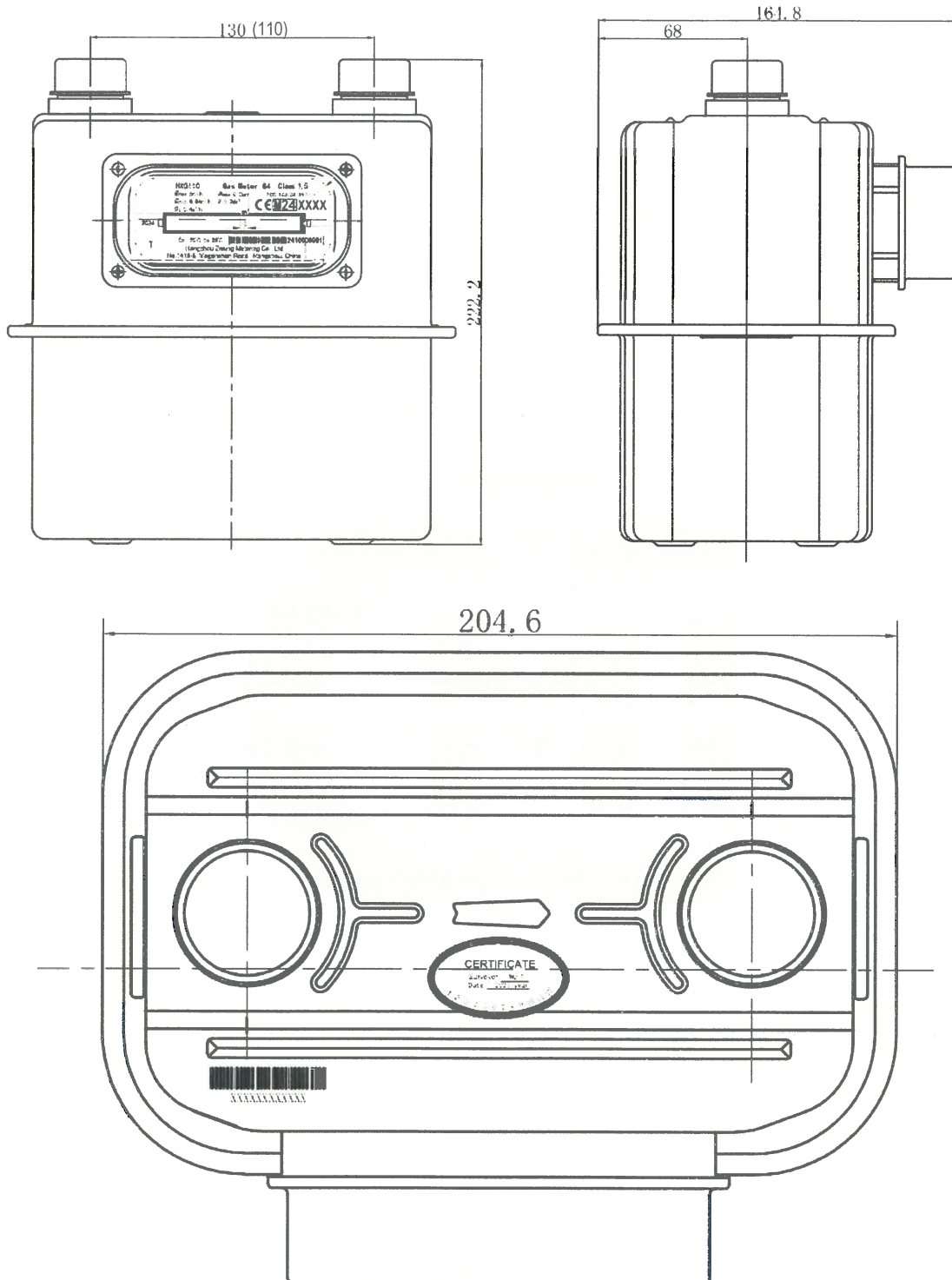

*Location of 2 seals on diaphragm gas meters HXG110 (G4, G2.5, G1.6):*

