



OIML Member State
Czech Republic

OIML Certificate No.
R137/2012-A-CZ1-24.04

OIML CERTIFICATE ISSUED UNDER SCHEME A

OIML Issuing Authority

Name: Czech Metrology Institute
Address: Okružní 31,
638 00 Brno
Czech Republic

Person responsible: Jan Kalandra

Applicant

Name: Hanwei Electronics Group Corporation
Address: No.169 Xuesong Road, National High-Tech Zone
450001 Zhengzhou
China

Manufacturer

Name: Hanwei Electronics Group Corporation
Address: No.169 Xuesong Road, National High-Tech Zone
450001 Zhengzhou
China

Identification of the certified type *(the detailed characteristics will be defined in the additional pages)*

diaphragm gas meter
type: ARJ1.6-SA, ARJ2.5-SA (G1.6., G2.5)

Designation of the module *(if applicable)*

This OIML Certificate attests the conformity of the above identified type (represented by the sample(s) identified in the OIML type evaluation report) with the requirements of the following Recommendation of the International Organization of Legal Metrology (OIML):

OIML R137

Edition (year): 2012, Including Amendment 2014

For accuracy class (if applicable): 1.5



This OIML Certificate relates only to metrological and technical characteristics of the type of measuring instrument covered by the relevant OIML Recommendation identified above.

This OIML Certificate does not bestow any form of legal international approval.

The conformity was established by the results of tests and examinations provided in the associated OIML type evaluation report:

- No. 0511-ER- P104-24 dated 18.9.2024 that includes 18 pages.
- Test Report No. 5012-PT-A0006-23 dated 5.6.2023 that includes 20 pages.

The technical documentation relating to the identified type is contained in documentation file:
0511-UL- P104-24

OIML Certificate History

Revision No.	Date	Description of the modification
-	25 September 2024	Issuing Certificate

Identification, signature and stamp

The OIML Issuing Authority

RNDr. Pavel Klenovský

Head of Certification Body

Date: 25 September 2024



Important note: Apart from the mention of the Certificate's reference number and the name of the OIML Member State in which the Certificate is issued, partial quotation of the Certificate and of the associated OIML type evaluation report(s) is not permitted, although either may be reproduced in full.

1 General information concerning the type

Information, indicated on the instrument	
Manufacturer's trade mark	HOWEST
Type designation	ARJ1.6-SA, ARJ2.5-SA (G1.6., G2.5)
Accuracy class	1.5
Cyclic volume (if applicable)	0.9 dm ³
Minimum pressure p_{min}	0 bar(g)
Maximum pressure p_{max}	0.5 bar(g)
Ambient temperature range	(-25 ... +55) °C
Gas temperature range	(-25 ... +55) °C
Base pressure (if applicable)	Not applicable
Base temperature (if applicable)	Not applicable
t_{sp} (if applicable)	Not applicable
Electrical power	Not applicable
Identification of software	Not applicable

Example of the labels:

Black

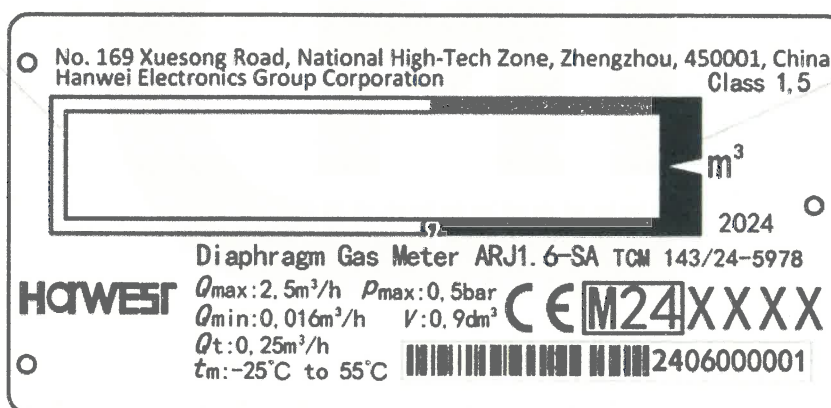

Red

Black

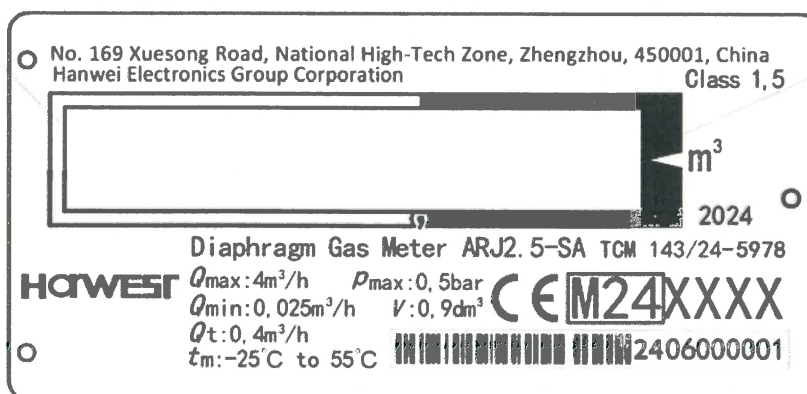

Red



Photos of the constructions:



2 Additional information concerning the type

Size G	Q_{max} (m ³ /h)	Q_t (m ³ /h)	Q_{min} (m ³ /h)	Cyclic volume V (dm ³)	Maximum permissible pressure loss ΔP in Q_{max} (Pa)	P_{max} (kPa)
G2.5	4.0	0.4	0.025	0.9	200	50
G1.6	2.5	0.25	0.016	0.9	200	50

The gas meter can be produced with the distance between connections (male threads):
130 mm, 110 mm, 90 mm

The male threads used in gas meters ARJ1.6-SA, ARJ2.5-SA (G1.6., G2.5): M30x2, G7/8", G3/4"

Dimensions of diaphragm gas meters ARJ1.6-SA, ARJ2.5-SA (G1.6., G2.5) (part 1/2)

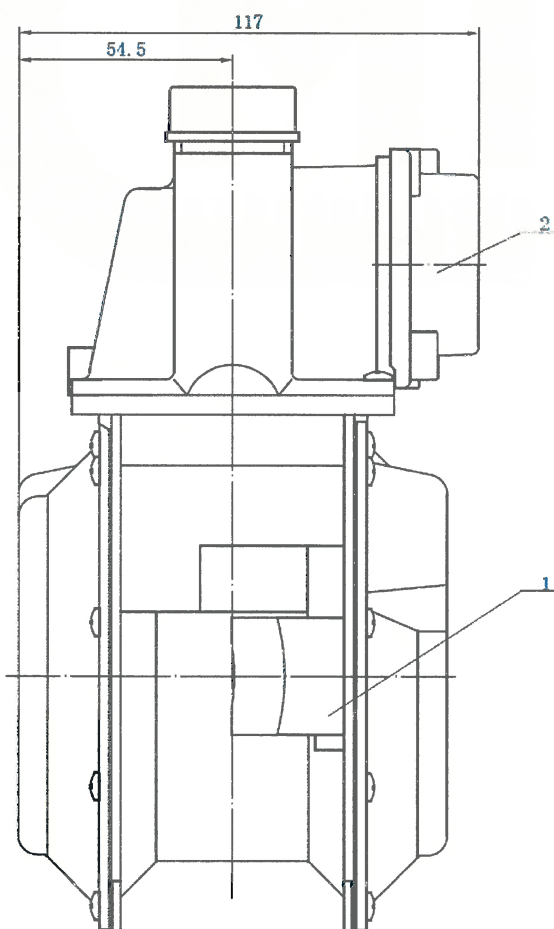
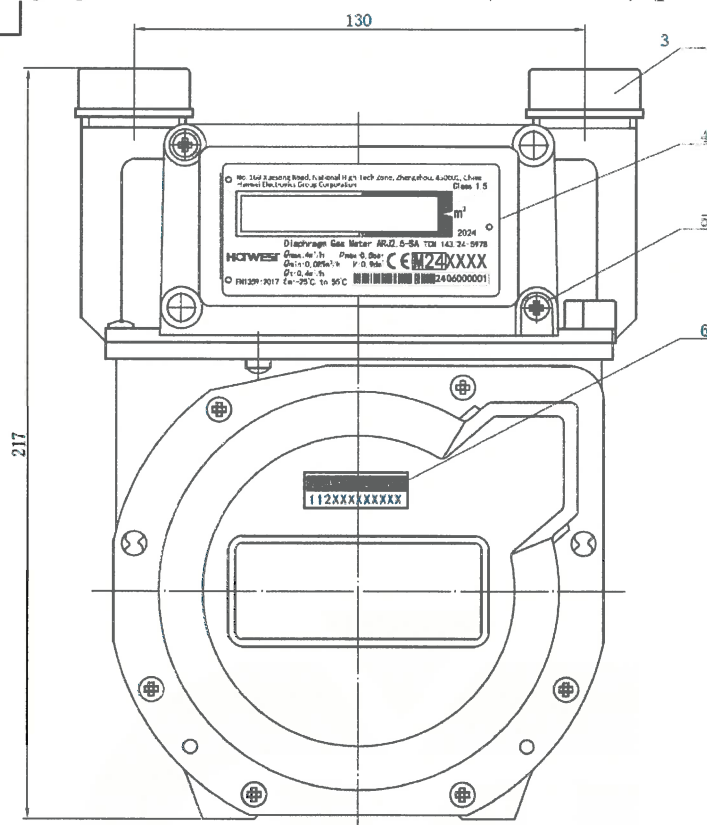

Dimensions of diaphragm gas meters ARJ1.6-SA, ARJ2.5-SA (G1.6., G2.5) (part 2/2)

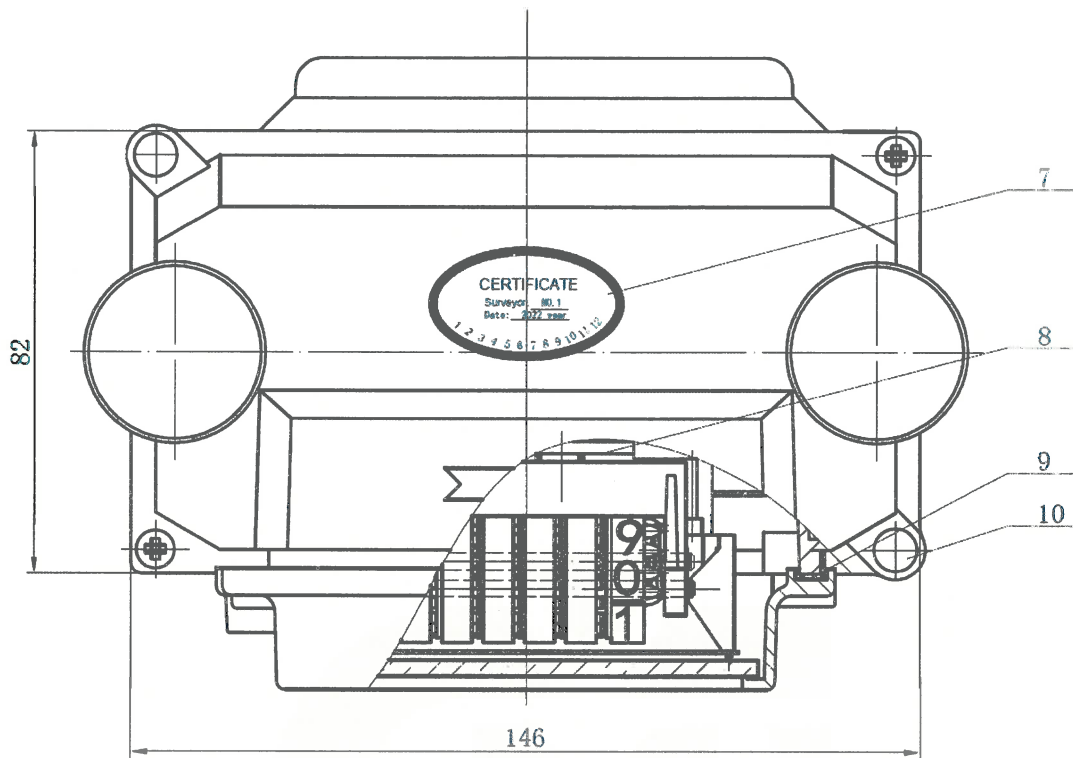

Location of 8 seals on diaphragm gas meters ARJ1.6-SA, ARJ2.5-SA (G1.6., G2.5):

