

OIML Member State
The Netherlands

Number R139/2018-A-NL1-21.04 revision 1
Project number 2573771
Page 1 of 6

Issuing authority
Person responsible: NMi Certin B.V.
M.Ph.D. Schmidt

Applicant and
Manufacturer: Dover Fueling Solutions UK limited (Filial)
Hanögatan 8
21124 Malmö
Sweden

Identification of the
certified type: A **CG dispenser** (compressed gas)
Type: Helix CNG

Characteristics: See page 2 and further

This OIML Certificate is issued under scheme A.

This Certificate attests the conformity of the above identified type (represented by the sample(s) identified in the OIML Type Evaluation Report) with the requirements of the following Recommendation of the International Organization of Legal Metrology (OIML):

R 139-1 (2018) "Compressed gaseous fuel measuring systems for vehicles"

Accuracy class: 1,5

This Certificate relates only to the metrological and technical characteristics of the type of measuring instrument covered by the relevant OIML International Recommendation identified above. This Certificate does not bestow any form of legal international approval.

This certificate and supporting reports comply with the requirements of OIML-CS-PD-07 clause 6.2.

Important note: Apart from the mention of the Certificate's reference number and the name of the OIML Member State in which the Certificate was issued, partial quotation of the Certificate and of the associated OIML Type Evaluation Report(s) is not permitted, although either may be reproduced in full.

Issuing Authority: **NMi Certin B.V., OIML Issuing Authority NL1**
29 October 2021

Certification Board

This document is issued under the provision that no liability is accepted and that the applicant shall indemnify third-party liability.

The notification of NMi Certin B.V. as Issuing Authority can be verified at www.oiml.org

This document is digitally signed and sealed. The digital signature can be verified in the blue ribbon at the top of the electronic version of this certificate.



OIML Member State
The Netherlands

Number R139/2018-A-NL1-21.04 revision 1
Project number 2573771
Page 2 of 6

The conformity was established by the results of tests and examinations provided in the associated report(s):

- No. NMI-1901591-01 dated 18 June 2018 that includes 19 pages;
- No. NMI-2283414-01 dated 19 February 2021 that includes 34 pages.

Characteristics of the measuring instrument

In Table 1 the general characteristics of the measuring instrument are presented.
The construction of the measuring instrument is recorded in the Documentation folder no. T8935-1.

Table 1 General characteristics

Minimum – maximum flow rate	Within the flow ranges of the applicable measurement transducer, see table 2 or 3.	
Minimum measured quantity	CNGmass	1 kg
	CNG050	1 kg
Maximum pressure	CNGmass	350 bar(g)
	CNG050	317 or 345 bar(g) (depending on flange type)
Accuracy class	1.5	
Environmental classes	M1 / E2	
Ambient temperature range	-25 – +55 °C; non condensing humidity	
Product temperature range	CNGmass	-40 – +55 °C
	CNG050	-25 – +55 °C
Intended for the measurement of	Compressed Natural Gas	

OIML Member State
The Netherlands

Number R139/2018-A-NL1-21.04 revision 1
Project number 2573771
Page 3 of 6

Each measuring instrument consists at least of:

- One measurement transducer (meter);
- One calculating/indicating device (calculator).

The characteristics of the mentioned parts of the dispenser are presented at table 2 and higher.

The same housing of the dispenser can comprise of one or more measuring systems. When more than one measuring systems are in one housing, one calculating/indicating device may be a common part of the measuring systems.

When two transfer points apply for the same measurement transducer, only one can be applied at the same time.

When applying two measurement transducers and each measurement transducer is destined to deliver separately, this configuration has to be considered as two dispensers.

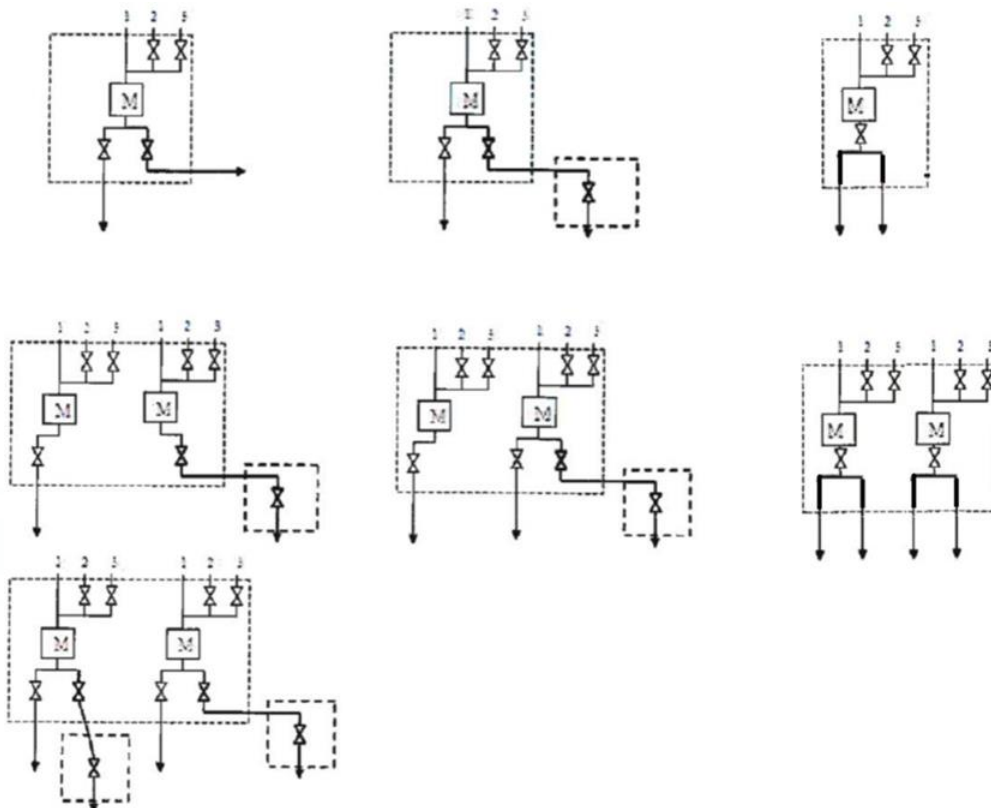

OIML Member State
The Netherlands

Number R139/2018-A-NL1-21.04 revision 1
Project number 2573771
Page 4 of 6

Parts of the measuring instrument

The conformity of the following parts was established by the results of tests and examinations provided in the associated report(s):

Part:	<u>Measurement transducer</u>
Producer:	Micro Motion
Type:	CNG050
Documentation folder:	TC11012-1
Reports:	No. C-BI-02-WV-0428 dated 28 May 2002 that includes 20 pages; No. CPC-92005574-2 dated 26 January 2010 that includes 12 pages; No. NMI-1900487-01 dated 17 July 2017 that includes 24 pages.

Table 2 General characteristics of the measurement transducer type CNG050

Flow rate range [kg/min]	1,3 – 77 kg/min
MMQ	1 kg
Maximum pressure	317 or 345 bar(g) (depending on flange type)
Environmental classes	M2 / E2
Ambient temperature range	-40 – +55 °C; non condensing humidity
Product temperature range	-25 – +55 °C
Intended for the measurement of	Compressed Natural Gas
Power supply	24 V DC \pm 20 % (with MVD Direct Connect I.S) 15 – 26 V DC
Software identification	Version number: 3.52 Checksum: 3C4A

Installation conditions measurement transducer type CNG050

Installation of the meter with the MVD Direct Connect barrier is preferred to protect against EMI.

OIML Member State
The Netherlands

Number R139/2018-A-NL1-21.04 revision 1
Project number 2573771
Page 5 of 6

Part: Measurement transducer
 Producer: Endress+Hauser Flowtec AG
 Type: CNGmass
 Documentation folder: TC10997-1
 Reports: No. CPC-10200012-01 dated 8 February 2010 that includes 23 pages;
 No. NMI-16200831-01 dated 7 July 2017 that includes 41 pages;
 No. NMI-16200831-02 dated 19 July 2017 that includes 17 pages.

Table 3 General characteristics of the measurement transducer type CNGmass

Flow rate range [kg/min]	See table 3 below
MMQ	See table 3 below
Maximum pressure	350 bar(g)
Environmental classes	M2 / E2
Ambient temperature range	-40 – +55 °C; non condensing humidity
Product temperature range	-50 – +125 °C
Intended for the measurement of	Compressed Natural Gas
Power supply	26 V AC; 50/60 Hz 24 V DC
Software identification	Version number: 01.01.00 Checksum: 0X13BD2D46

Table 4 General characteristics of the family of instruments type CNGmass

Meter size	DN08	DN15	DN25
Minimum flow rate [kg/min]	0,3	0,8	1,5
Maximum flow rate [kg/min]	30	80	150
MMQ [kg]	1	1	1
Maximum pressure [bar(g)]	250	250	250
Diameter in/outlet [mm]	8	15	25

OIML Member State
The Netherlands

Number R139/2018-A-NL1-21.04 revision 1
Project number 2573771
Page 6 of 6

Part: Calculating/indicating device
 Producer: Dover Fueling Solutions
 Type: OPT-ELT
 Documentation folder: TC8942-1
 Reports: No. CPC-805983 dated 24 June 2008 that includes 48 pages;
 No. NMI-15200585-01 dated 17 March 2016 that includes 29 pages;
 No. NMI-1901591-01 18 June 2018 that includes 19 pages;
 No. NMI-2283414-01 19 February 2021 that includes 34 pages.

Table 5 General characteristics of the calculating/indicating device type OPT-ELT

Maximum weight indication	xxx.xx digits
Maximum unit price	xxxx digits
Maximum price to pay	xxxxxx digits
Environmental classes	M1 / E2
Ambient temperature range	-40 °C / +55 °C (for OPT-ELT with display part no. WM063074-0001) -25 °C / +55 °C (for OPT-ELT with display part no. WT009754-0001(TSO33108) and WT009754-0002(TSO33121))
Software identification	TOS01802.xxx or TOS002zzz.xx
Power supply	230 V AC (+10% -25%) 50-60 Hz

Production location

The dispenser is produced at one of the following production locations:

- Dover Fueling Solutions UK limited (Filial), Hanögatan 8, 21124 Malmö, Sweden
- Dover Fueling Solutions UK, Unit 3, Baker Road, Dundee, DD5 3RT, Scotland, UK
- Tokheim India Private Limited, Building No 2, Plot 66 TTC Industrial Area, MIDC, Mahape, Navi Mumbai 400 710, Maharashtra, India

It is the decision and responsibility of the manufacturer Dover Fueling Solutions in which location the CNG dispensers are produced.

Certificate history:

This revision replaces the previous version.

Revision	Date	Description of the modification
Initial	30 September 2021	-
1	29 October 2021	Editorial changes.