



OIML Member State
SLOVAKIA

OIML Certificate No.
R49/2013-A-SK1-2023.02 Rev. 1

OIML CERTIFICATE ISSUED UNDER SCHEME A

OIML Issuing Authority

Name: **Slovak Legal Metrology (SLM)**
Address: Hviezdoslavova 1124/31, 974 01 Banská Bystrica, Slovakia
Person responsible: Peter Vook, Director

Applicant

Name: **UAB „Axioma Metering“**
Address: Veterinaru str. 52, Biruliskes,
LT-54469 Kaunas region,
Lithuania

Manufacturer

Name: **UAB „Axioma Metering“**
Address: Veterinaru str. 52, Biruliskes,
LT-54469 Kaunas region,
Lithuania

Identification of the certified type *(the detailed characteristics are defined in the additional pages)*

Water meter type **Qalcosonic W1**

Designation of the module *(if applicable)*

Ultrasonic water meters with electronic indication device

This OIML Certificate attests the conformity of the above identified type (represented by the sample(s) identified in the OIML type evaluation report) with the requirements of the following Recommendation of the International Organization of Legal Metrology (OIML):

OIML R 49, Edition (year): 2013
For accuracy class (if applicable): 2



This OIML Certificate relates only to metrological and technical characteristics of the type of measuring instrument covered by the relevant OIML Recommendation identified above.

This OIML Certificate does not bestow any form of legal international approval.

The conformity was established by the results of tests and examinations provided in the associated OIML type evaluation report:

No. 2022/ER010/SK1 dated 13th January 2023 that includes 17 pages.

The technical documentation relating to the identified type is contained in documentation file name: „Technical documentation file AXIOMA_Qalcosonic W1_00“ dated 13th January 2023 that includes 114 pages.

OIML Certificate History

Revision No.	Date	Description of the modification
0	13 th January 2023	Certificate first issued
1	25 th May 2023	Point 2.4 Software specification – supplemented specification for all DNs separately

Identification, signature and stamp

The OIML Issuing Authority



.....
Peter Vook

Date: 25th May 2023

Important note: Apart from the mention of the Certificate's reference number and the name of the OIML Member State in which the Certificate is issued, partial quotation of the Certificate and of the associated OIML type evaluation report(s) is not permitted, although either may be reproduced in full.

1. Designation

The ultrasonic water meter type QALCOSONIC W1 is designed to measure, memorise and display the volume of water passing through the measurement transducer at metering conditions. The water meter is intended for the measurement of volume of clean water in residential use and is intended for non-resettable measurements between two constant partners.

The water meter type QALCOSONIC W1 is compact ultrasonic water meter with electronic indication device. The measurement is based on ultrasonic measurement method, bidirectional transit-time principle. Ultrasonic signal moves along the measuring section many times and the flow downstream between the ultrasonic sensors have to perform transmitter and receiver functions. From the results of time difference the flow rate is calculated and indicated in display.

The water meter type QALCOSONIC W1 can be installed to operate in horizontal and vertical positions and is not designed to measure the reverse flow.

2. Description

2.1 Parts of the water meter type QALCOSONIC W1

Essential parts of the water meter:

- Flow sensor:
 - the plastic cylindrical brass body with inlet and outlet firmly connected with the plastic housing for the calculator;
 - the inner plastic element with two mirrors (sound path) placed in the cylindrical plastic body;
 - two ultrasonic transducers placed on the upside of the cylindrical plastic body.
- Calculator and indication device:
 - the plastic housing of the calculator with indication device directly mounted on the flow sensor;
 - the PCB boards - tree PCB and one PCB with calculator;
 - the electronic LCD display with 2-lines:
 - o upper line with 9 digits and indication range of 999999.999 m³. The sub-multiples of a cubic meter are indicated on the LCD display by tree smaller digits after decimal point;
 - o bottom line with 5 digits to display the current flow rate in m³/h.
 - non-replaceable lithium batteries, life 16 years. The end of battery life is visible on plate of water meter:
 - o for DN15, DN20, DN25, DN32 two internal baterries „AA:size“;
 - o for DN15, DN20, DN25, DN32: two internal batteries „AA“ size + one „A23“;
 - o for DN40 one internal battery „D“ size;
 - o for DN40 one internal battery „D“ size + one “A23”.

Non-essential parts of the water meter:

- antenna;
- non-return valve – optionally.

2.2 Metrological functions

- measuring, memorizing and displaying the volume of water passing through the water meter.



2.3 Operation and presentation of legal data

- a) the total measured volume (m³);
- b) flow rate (m³/h).

The following displays are available by the configuration program "W1 TOOL":

- forward flow volume;
- volume of total reverse flow;
- water temperature value;
- date;
- real time;
- status error code;
- accumulated volume on set day and time;
- segment tests – full screen;
- segment test – blank screen;
- user indication number;
- control number;
- verification mode.

2.4 Software specification

Software versions	Checksum	Remarks
1.03	C983	DN15, DN20, DN25, DN32
2.02	CD00	DN40

The software version is indicated on the data plate in the form SW:1.03 (SW: 2.02).

The checksum is indicated on the data plate in the form C983 (CD00).

2.5 Accountable alarms

During the measuring process the calculator and indication device detects automatically if a fault condition occurs and eventually stops the measurement reporting an alarm indication on the display. See user manual issued by the manufacturer.



3. Technical and metrological data

Tab. 1

Type /model		<i>QALCOSONIC W1</i>									
Nominal diameter DN	mm	15									
Permanent flowrate Q_3	m ³ /h	1,6					2,5				
Minimum flowrate Q_1	m ³ /h	0,020	0,010	0,0064	0,005	0,004	0,031	0,0156	0,010	0,0062	0,0031
Transitional flowrate Q_2	m ³ /h	0,032	0,016	0,010	0,008	0,0064	0,050	0,025	0,016	0,010	0,005
Overload flowrate Q_4	m ³ /h	2					3,125				
Ratio Q_3/Q_1	-	80	160	250	315	400	80	160	250	400	800
Ratio Q_2/Q_1	-	1,6									
Connection thread	-	G ¾									
Construction length L	mm	80, 105, 110, 115, 165, 170									
Installation position	-	Horizontal / Vertical									
Water temperature range	°C	0,1 to 30 0,1 to 50 30 to 70 0,1 to 70									
Meter temperature class	-	T30 T50 T30/70 T70									
Maximum working pressure MAP	bar	16									
Pressure loss class ΔP	bar	0,16					0,25				
Maximum permissible error in upper flowrates range $Q_2 \leq Q \leq Q_4$	%	± 2 (at $\theta \leq 30^\circ\text{C}$) ± 3 (at $\theta > 30^\circ\text{C}$)									
Maximum permissible error in lower flowrates ranges $Q_1 \leq Q < Q_2$	%	± 5									
Scale interval	m ³	0,001									
Capacity of calculator	m ³	999999,999									
Accuracy class	-	2									
Mechanical class	-	M1									
Climatic class	°C	-15 to +70									
Electromagnetic class	-	E2									
Environmental classification	-	B/O									
Flow profile sensitivity class	-	U0D0									
Battery	-	li-battery 3,6 V, life time 16 years									



Tab. 2

Type /model		<i>QALCOSONIC WI</i>									
Nominal diameter DN	mm	20									
Permanent flowrate Q_3	m ³ /h	2,5					4				
Minimum flowrate Q_1	m ³ /h	0,031	0,0156	0,010	0,0062	0,050	0,025	0,016	0,010	0,005	
Transitional flowrate Q_2	m ³ /h	0,05	0,025	0,016	0,010	0,080	0,040	0,026	0,016	0,008	
Overload flowrate Q_4	m ³ /h	3,125					5				
Ratio Q_3/Q_1	-	80	160	250	400	80	160	250	400	800	
Ratio Q_2/Q_1	-	1,6									
Connection thread	-	G 1									
Construction length L	mm	105, 110, 130, 165, 190									
Installation position	-	Horizontal / Vertical									
Water temperature range	°C	0,1 to 30 0,1 to 50 30 to 70 0,1 to 70									
Meter temperature class	-	T30 T50 T30/70 T70									
Maximum working pressure	bar	16									
Pressure loss ΔP	bar	0,16					0,25				
Maximum permissible error in upper flowrates range $Q_2 \leq Q \leq Q_4$	%	± 2 (at $\theta \leq 30^\circ\text{C}$) ± 3 (at $\theta > 30^\circ\text{C}$)									
Maximum permissible error in lower flowrates ranges $Q_1 \leq Q < Q_2$	%	± 5									
Scale interval	m ³	0,001									
Capacity of calculator	m ³	999999,999									
Accuracy class	-	2									
Mechanical class	-	M1									
Climatic class	°C	-15 to +70									
Electromagnetic class	-	E2									
Environmental classification	-	B/O									
Flow profile sensitivity class	-	U0D0									
Battery	-	li-battery 3,6 V, life time 16 years									



Tab. 3

Type /model	<i>QALCOSONIC WI</i>									
Nominal diameter DN	mm	25								
Permanent flowrate Q ₃	m ³ /h	6,3				10				
Minimum flowrate Q ₁	m ³ /h	0,079	0,040	0,252	0,016	0,125	0,0625	0,040	0,025	
Transitional flowrate Q ₂	m ³ /h	0,126	0,063	0,040	0,026	0,200	0,100	0,064	0,040	
Overload flowrate Q ₄	m ³ /h	7,875				12,5				
Ratio Q ₃ /Q ₁	-	80	160	250	400	80	160	250	400	
Ratio Q ₂ /Q ₁	-	1,6								
Connection thread	-	G 1 ¼								
Construction length L	mm	260								
Installation position	-	Horizontal / Vertical								
Water temperature range	°C	0,1 to 30 0,1 to 50 30 to 70 0,1 to 70								
Meter temperature class	-	T30 T50 T30/70 T70								
Maximum working pressure	bar	16								
Pressure loss ΔP	bar	0,25				0,63				
Maximum permissible error in upper flowrates range Q ₂ ≤ Q ≤ Q ₄	%	± 2 (at θ ≤ 30°C) ± 3 (at θ > 30°C)								
Maximum permissible error in lower flowrates ranges Q ₁ ≤ Q < Q ₂	%	± 5								
Scale interval	m ³	0,001								
Capacity of calculator	m ³	999999,999								
Accuracy class	-	2								
Mechanical class	-	M1								
Climatic class	°C	-15 to +70								
Electromagnetic class	-	E2								
Environmental classification	-	B/O								
Flow profile sensitivity class	-	U0D0								
Battery	-	li-battery 3,6 V, life time 16 years								



Tab. 4

Type /model	<i>QALCOSONIC W1</i>								
Nominal diameter DN	mm	32							
Permanent flowrate Q ₃	m ³ /h	6,3				10			
Minimum flowrate Q ₁	m ³ /h	0,079	0,040	0,0252	0,016	0,125	0,0625	0,025	
Transitional flowrate Q ₂	m ³ /h	0,126	0,063	0,040	0,026	0,200	0,100	0,040	
Overload flowrate Q ₄	m ³ /h	7,875				12,5			
Ratio Q ₃ /Q ₁	-	80	160	250	400	80	160	400	
Ratio Q ₂ /Q ₁	-	1,6							
Connection thread	-	G 1 ½							
Construction length L	mm	260							
Installation position	-	Horizontal / Vertical							
Water temperature range	°C	0,1 to 30 0,1 to 50 30 to 70 0,1 to 70							
Meter temperature class	-	T30 T50 T30/70 T70							
Maximum working pressure	bar	16							
Pressure loss ΔP	bar	0,16				0,25			
Maximum permissible error in upper flowrates range Q ₂ ≤ Q ≤ Q ₄	%	± 2 (at θ ≤ 30°C) ± 3 (at θ > 30°C)							
Maximum permissible error in lower flowrates ranges Q ₁ ≤ Q < Q ₂	%	± 5							
Scale interval	m ³	0,001							
Capacity of calculator	m ³	999999,999							
Accuracy class	-	2							
Mechanical class	-	M1							
Climatic class	°C	-15 to +70							
Electromagnetic class	-	E2							
Environmental classification	-	B/O							
Flow profile sensitivity class	-	U0D0							
Battery	-	li-battery 3,6 V, life time 16 years							



Tab. 5

Type /model		<i>QALCOSONIC WI</i>											
Nominal diameter DN	mm	40											
Permanent flowrate Q_3	m^3/h	10			16				25				
Minimum flowrate Q_1	m^3/h	0,125	0,0625	0,040	0,200	0,100	0,064	0,040	0,3125	0,156	0,100	0,0625	
Transitional flowrate Q_2	m^3/h	0,200	0,100	0,064	0,320	0,160	0,102	0,064	0,500	0,250	0,160	0,100	
Overload flowrate Q_4	m^3/h	12,5			20,0				31,25				
Ratio Q_3/Q_1	-	80	160	250	80	160	250	400	80	160	250	400	
Ratio Q_2/Q_1	-	1,6											
Connection thread	-	G 2											
Construction length L	Mm	300											
Installation position	-	Horizontal / Vertical											
Water temperature range	$^{\circ}C$	0,1 to 30 0,1 to 50 30 to 70 0,1 to.70											
Meter temperature class	-	T30 T50 T30/70 T70											
Maximum working pressure	Bar	16											
Pressure loss ΔP	Bar	0,16											
Maximum permissible error in upper flowrates range $Q_2 \leq Q \leq Q_4$	%	± 2 (at $\theta \leq 30^{\circ}C$) ± 3 (at $\theta > 30^{\circ}C$)											
Maximum permissible error in lower flowrates ranges $Q_1 \leq Q < Q_2$	%	± 5											
Scale interval	m^3	0,001											
Capacity of calculator	m^3	999999,999											
Accuracy class	-	2											
Mechanical class	-	M1											
Climatic class	$^{\circ}C$	-15 to +70											
Electromagnetic class	-	E2											
Environmental classification	-	B/O											
Flow profile sensitivity class	-	U0D0											
Battery	-	li-battery 3,6 V, life time 16 years											



4. Marking and inscriptions

The following data shall be marked on the water meter:

- a) name or trademark of the manufacturer;
- b) type name of the water meter;
- c) unit of measurement m^3 ;
- d) year of manufacture, the last two digits of the year of manufacture, or the month and year of manufacture;
- e) serial number (as near as possible to the indicating device);
- f) direction of flow, by means of an arrow (shown on both sides of the body or on one side only provided the direction of flow arrow is easily visible under all circumstances);
- g) flowrate Q_3 and ratio Q_3/Q_1 indicated as (R) followed by the ratio value;
- h) maximum admissible pressure (MAP);
- i) temperature class;
- j) pressure loss class (Δp);
- k) the latest date by which the meter shall be replaced;
- l) environmental classification;
- m) installation sensitivity class;
- n) electromagnetic environmental class;
- o) flow profile sensitivity class
- p) type approval sign according to national regulations.

5. Security measures

The water meter shall be protected against unauthorised manipulation and opening as follows:

- by the wire with a seal securing the connection between the upper cover and the housing;
- the meter casing is imperceptibly closed.

When the upper sealed cover is opened, the safety button that installed in the meter body is activated and error code appears on the meter display. (Fig.: 2).



6. Figures



Figure 1: Illustrative views of the water meters type QALCOSONIC W1

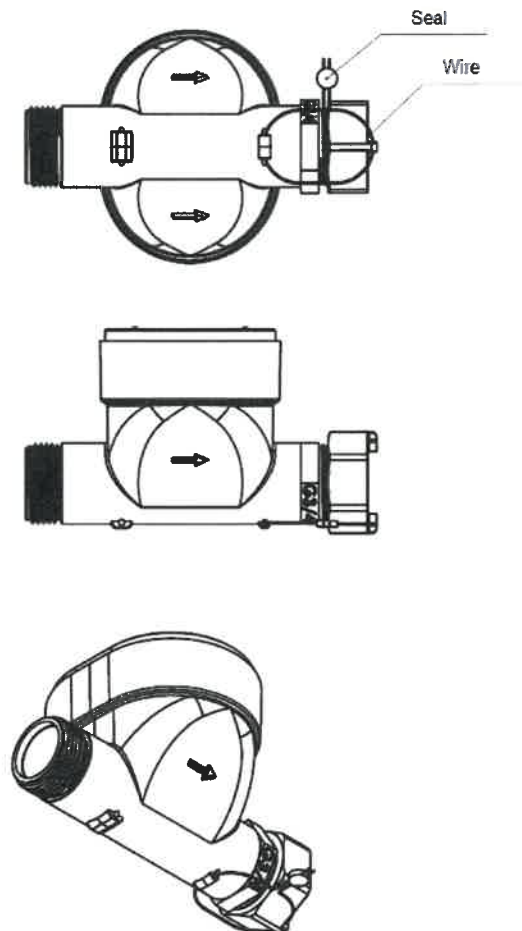

Fig. 2a) Sealing DN15 and DN20

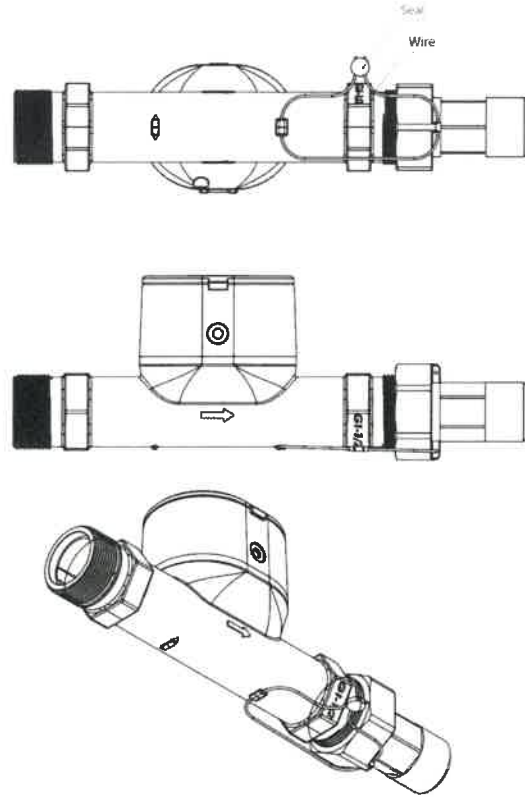

Fig. 2b) Sealing DN25 and DN32

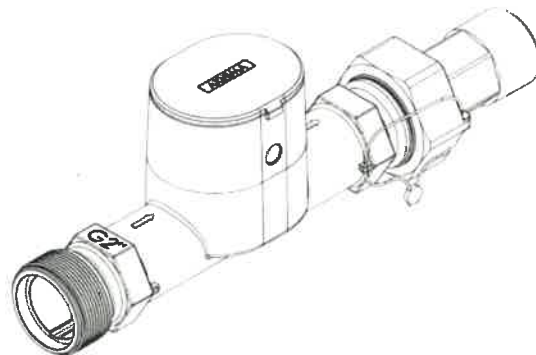
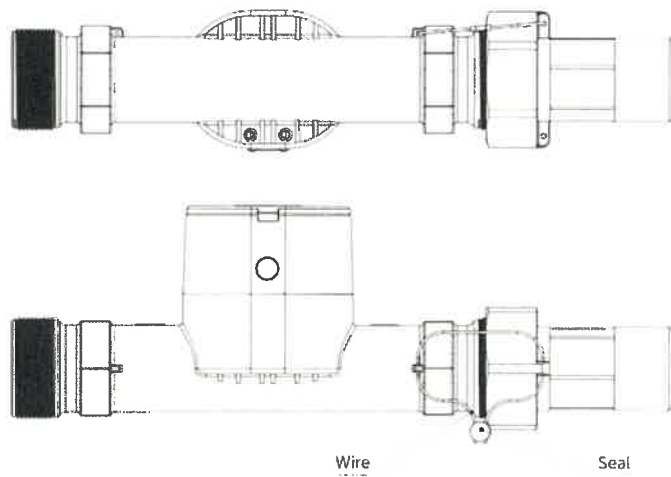

Fig. 2c) Sealing DN40