



OIML Member State  
SLOVAKIA

OIML Certificate No.  
R49/2013-A-SK1-2024.01 Rev. 1

**OIML CERTIFICATE ISSUED UNDER SCHEME A**

**OIML Issuing Authority**

Name: **Slovak Legal Metrology (SLM)**  
Address: **Hviezdoslavova 1124/31, 974 01 Banská Bystrica, Slovakia**  
Person responsible: **Dušan Šmigura, Director of PCB**

**Applicant**

Name: **Shenzhen Kaifa Technology (Chengdu) Co., Ltd.**  
Address: **No. 99 Tianquan Road., Hi-Tech Development Zone  
Chengdu City, Sichuan Province, P.R. China**

**Manufacturer**

Name: **Shenzhen Kaifa Technology (Chengdu) Co., Ltd.**  
Address: **No. 99 Tianquan Road., Hi-Tech Development Zone  
Chengdu City, Sichuan Province, P.R. China**

**Identification of the certified type** (the detailed characteristics are defined in the additional pages)

Water meter type **MA408**

**Designation of the module** (if applicable)

Ultrasonic water meters with electronic indication device

This OIML Certificate attests the conformity of the above identified type (represented by the sample(s) identified in the OIML type evaluation report) with the requirements of the following Recommendation of the International Organization of Legal Metrology (OIML):

OIML R 49, Edition (year): 2013  
For accuracy class (if applicable): 1 and 2



**OIML Certificate No.  
R49/2013-A-SK1-2024.01 Rev. 1**

This OIML Certificate relates only to metrological and technical characteristics of the type of measuring instrument covered by the relevant OIML Recommendation identified above.

This OIML Certificate does not bestow any form of legal international approval.

The conformity was established by the results of tests and examinations provided in the associated:

OIML Test report No. 2023/CV025/312.15 dated 15<sup>th</sup> April 2024 that includes 76 pages;  
OIML Type Evaluation Report No. 2023/ER025/SK1\_Rev. 1 dated 17<sup>th</sup> June 2024 that includes 16 pages.

The technical documentation relating to the identified type is contained in documentation file name:

- „Technical documentation file Shenzhen Kaifa\_MA408\_00“ dated 22<sup>nd</sup> April 2024 that includes a sum of documents 93 pages.

**OIML Certificate History**

Revision No.	Date	Description of the modification
0	22 <sup>nd</sup> April 2024	Certificate first issued /
1	17 <sup>th</sup> June 2024	OIML Certificate R49/2013-A-SK1-2024.01 of 22 <sup>nd</sup> April 2024, page 5: - Capacity of calculator: add. testing mode - Scale interval (high resolution) corrected 0,0000001 to 0,000001 OIML Type Evaluation Report 2023/ER025/SK1 of 22 <sup>nd</sup> April 2024 page 8: - Test mode corrected 0,0000001 to 0,000001

Identification, signature and stamp

**The OIML Issuing Authority**



.....  
Dušan Šmigura

Date: 17<sup>th</sup> June 2024

**Important note:** Apart from the mention of the Certificate's reference number and the name of the OIML Member State in which the Certificate is issued, partial quotation of the Certificate and of the associated OIML type evaluation report(s) is not permitted, although either may be reproduced in full.

## 1. Designation

The ultrasonic water meter **MA408** is designed to measuring, memorizing and displaying the volume of water passing through the measurement transducers at metering conditions. The water meter is intended for the measurement of volume of clean water in residential use.

The water meter MA408 is residential compact ultrasonic water meters with electronic indication device. The measurement is based on ultrasonic bidirectional transit-time principle. The flow is measured by the difference in time-of-flight of ultrasonic pulses with flow (downstream) and opposite to flow (upstream).

The water meter MA408 can be installed to operate in horizontal and vertical positions. The water meters are not designed to measure the reverse flow.

## 2. Description

### 2.1 Parts of the water meters MA408

Essential parts:

Flow sensor:

- the brass cylindrical body with inlet and outlet firmly with the plastic housing for the calculator;
- the inner plastic elements-measuring support (pipe support-down and pipe support-up) placed in the cylindrical brass body;
- two reflection sheeds installed in the centre of the pipe;
- two ultrasonic transducers at the upstream and downstream of the measurement channel (pipe section) to transmit and receive ultrasonic signals.

Calculator and indication device:

- the plastic housing of the calculator with indication device directly mounted on the flow sensor;
- two PCB boards:
  - main PCB board,
  - measurement PCB board
- the electronic scrolling LCD display (by button) with 9 digits and indication range of 999999,999 m<sup>3</sup>. The sub-multiples of a cubic meter are indicated on the LCD display with a box around three digits after the decimal point;
- one non-replaceable lithium battery for metering, lifetime 10 years.

Non-essential parts of the water meters:

- strainer;
- the optical port for communication;
- one battery for communication.

### 2.2 Metrological functions

- measuring, memorizing and displaying the volume of water passing through the water meter.



### 2.3 Operation and presentation of legal data

- the total measured volume (m<sup>3</sup>);
- flow rate (m<sup>3</sup>/h).

The following displays are available on the scroll display too:

- display test (an “eights” test);
- display test (a “blanks” test);
- forward consumption volume (m<sup>3</sup>);
- the last value for charge (m<sup>3</sup>) with date (MM-DD-YY);
- the total charge values (m<sup>3</sup>) reserved for prepay mode;
- real time (h/min/s) and date reserved for prepay mode (MM-DD-YY);
- test mode:
  - o forward accumulated consumption in the test mode;
  - o flow rate in the test mode;
  - o error code;
  - o tariff;
  - o software version and checksum;
  - o serial number;
  - o battery voltage and capacity;
  - o pressure value and water temperature.

### 3. Software specification

The legally relevant software version and checksum for water meters MA408:

Software versions	Checksum	Remarks
1029	A7F64A89	

The software version and checksum can be checked using the scrolling display.

### 4. Accountable alarms

If a fault condition occurs and the measurement stops, follow the user manual issued by the manufacturer.



## 5. Technical and metrological data

Water meter type		MA408		
Characteristics	Unit	DN15	DN20	DN25
Nominal diameter DN	mm	DN15	DN20	DN25
Permanent flowrate $Q_3$	m <sup>3</sup> /h	2,5	4	6,3
Minimum flowrate $Q_1$	m <sup>3</sup> /h	0,00625	0,010	0,01575
Transitional flowrate $Q_2$	m <sup>3</sup> /h	0,010	0,016	0,0252
Overload flowrate $Q_4$	m <sup>3</sup> /h	3,125	5	7,875
Ratio $Q_3/Q_1$	R	400		
Ratio $Q_2/Q_1$	-	1,6		
Connection thread	mm	G ¼ B	G1 B	G1 ¼ B
Construction length $L$	mm	165	190/195/165	225
Installation orientation	-	H/V		
Water temperature range (temperature class)	°C	0,1 to 50 (T50)		
Maximum admissible pressure MAP	bar	16		
Pressure loss class $\Delta p$	bar	0,40		
	-	$\Delta p$ 40		
Maximum permissible error in upper flowrates range $Q_2 \leq Q \leq Q_4$	%	± 2 (at $\theta \leq 30^\circ\text{C}$ ) ± 3 (at $\theta > 30^\circ\text{C}$ )		
Maximum permissible error in lower flowrates range $Q_1 \leq Q < Q_2$	%	± 5		
Capacity of calculator	m <sup>3</sup>	normal mode: 999999,999 testing mode: 999,999999		
Scale interval (normal resolution of the indicating device)	m <sup>3</sup>	0,001		
Scale interval (high resolution)	m <sup>3</sup>	0,000001		
Accuracy class	-	2		
Mechanical class	-	M1		
Climatic class	°C	- 25 to + 55		
Electromagnetic class	-	E1/E2		
Climatic and mechanical environmental conditions (class) according to EN ISO 4064-1/OIML R 49-1	-	B/O		
Flow profile sensitivity class	-	U0D0		
Battery	-	non-replaceable li-battery 3,8 V life time 10 years		

## 6. Marking and inscriptions

The following data shall be marked on the water meter:

- unit of measurement (m<sup>3</sup>);
- flowrate  $Q_3$  and ratio  $Q_3/Q_1$  (R);
- type of water meter;





- d) manufacturers name or trademark;
- e) year of manufacture or the month and year of manufacture;
- f) serial number;
- g) direction of flow, by means of an arrow (shown on both sides of the body or on one side only provided the direction of flow arrow is easily visible under all circumstances);
- h) maximum admissible pressure (MAP);
- i) letter V or H, if the meter can only be operated in the vertical or horizontal position;
- j) temperature class (T);
- k) pressure loss class ( $\Delta p$ );
- l) installation sensitivity class where it different from U0/D0;
- m) for a non-replaceable battery, the latest date by which the meter shall be replaced;
- n) environmental classification (can be given on a document supplied separately);
- o) electromagnetic environmental class (can be given on a document supplied separately);
- p) type approval sign according to national regulations.

## 7. Security measures

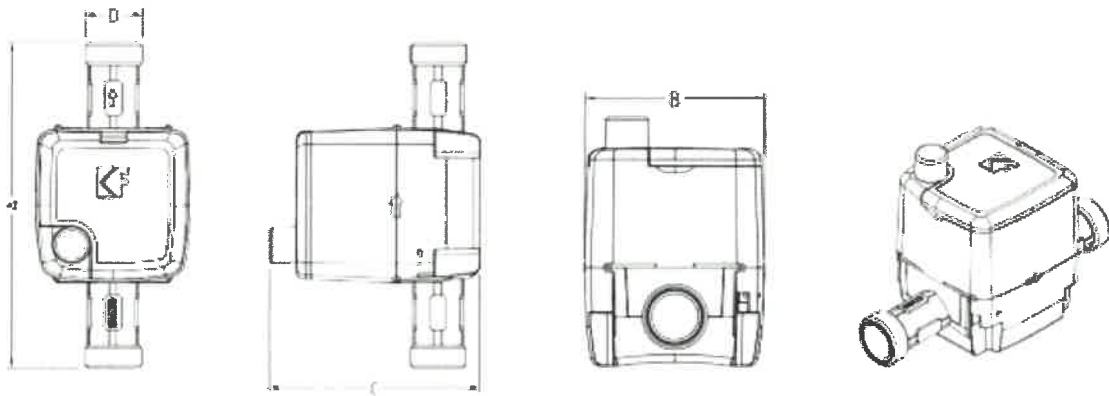
The water meters MA408 shall be protected against unauthorized manipulation and opening by:

- two seals with the wire ensuring the connection of the upper cover (prevents access to the PCB and software) with the lower part of the water meter (contains the body of the water meter).

## 8. Figures

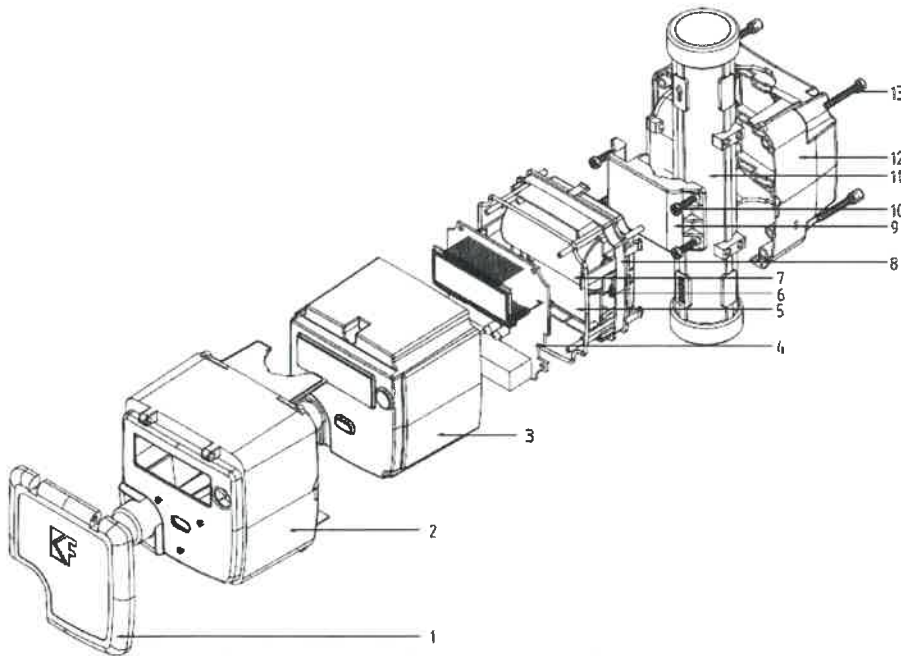


Fig. 1: Illustrative views of the water meter type MA408



DN	in	A	B	C
		mm	mm	mm
15	1/2	165	90	125
20	3/4	190	90	125
25	1	225	90	125

Fig. 2: Dimensions of water meter type MA408



10	-	screw M3,8x10	1
11	-	Base cover	1
12	-	Pipe	1
13	-	screw M3,8x10	1
09	-	Pressing plate	1
08	-	Base cover-inner box	1
07	-	Battery	1
06	-	Seat ring	1
05	-	Metrology board	1
04	-	Main Board	1
03	-	Top cover-inner box	1
02	-	Top cover	1
01	-	flip case	1
No	P/N	Description	quantity

Fig. 3: Exploded view of water meter type MA408