



OIML Member State
SLOVAKIA

OIML Certificate No.
R49/2013-A-SK1-2024.03

OIML CERTIFICATE ISSUED UNDER SCHEME A

OIML Issuing Authority

Name: **Slovak Legal Metrology (SLM)**
Address: Hviezdoslavova 1124/31, 974 01 Banská Bystrica, Slovakia
Person responsible: Dušan Šmigura, Director of PCB

Applicant

Name: **Shenzhen Kaifa Technology (Chengdu) Co., Ltd.**
Address: No. 99 Tianquan Road., Hi-Tech Development Zone
Chengdu City, Sichuan Province, P.R. China

Manufacturer

Name: **Shenzhen Kaifa Technology (Chengdu) Co., Ltd.**
Address: No. 99 Tianquan Road., Hi-Tech Development Zone
Chengdu City, Sichuan Province, P.R. China

Identification of the certified type *(the detailed characteristics are defined in the additional pages)*

Water meter type **MA408K**

Designation of the module *(if applicable)*

Ultrasonic water meters with electronic indication device

This OIML Certificate attests the conformity of the above identified type (represented by the sample(s) identified in the OIML type evaluation report) with the requirements of the following Recommendation of the International Organization of Legal Metrology (OIML):

OIML R 49, Edition (year): 2013
For accuracy class (if applicable): 1 and 2



**OIML Certificate No.
R49/2013-A-SK1-2024.03**

This OIML Certificate relates only to metrological and technical characteristics of the type of measuring instrument covered by the relevant OIML Recommendation identified above.

This OIML Certificate does not bestow any form of legal international approval.

The conformity was established by the results of tests and examinations provided in the associated:

OIML Test Report No. 2024/CV007/312.15 dated 22nd April 2024 that includes 30 pages;
OIML Type Evaluation Report No. 2024/ER007/SK1 dated 17th May 2024 that includes 16 pages.

The technical documentation relating to the identified type is contained in documentation file name:

- „Technical documentation file Shenzhen Kaifa_MA408K_00“ dated 17th May 2024 that includes a sum of documents 49 pages.

OIML Certificate History

Revision No.	Date	Description of the modification
0	17 th May 2024	Certificate first issued
-	-	-

Identification, signature and stamp

The OIML Issuing Authority



.....
Dušan Šmigura

Date: 17th May 2024

Important note: Apart from the mention of the Certificate's reference number and the name of the OIML Member State in which the Certificate is issued, partial quotation of the Certificate and of the associated OIML type evaluation report(s) is not permitted, although either may be reproduced in full.

1. Designation

The ultrasonic water meter **MA408K** is designed to measuring, memorizing and displaying the volume of water passing through the measurement transducers at metering conditions. The water meter is intended for the measurement of volume of clean water in residential use.

The water meter MA408K is residential compact ultrasonic water meters with electronic indication device added with internal valve for local control and remote control. The measurement is based on ultrasonic bidirectional transit-time principle.

The flow is measured by the difference in time-of-flight of ultrasonic pulses with flow (downstream) and opposite to flow (upstream).

The water meter MA408K can be installed to operate in horizontal and vertical positions. The water meter is not designed to measure the reverse flow.

2. Description

2.1 Parts of the water meters MA408K

Essential parts:

Flow sensor:

- the brass cylindrical body with inlet and outlet firmly with the plastic housing for the calculator;
- the inner plastic elements-measuring support (pipe support-down and pipe support-up) placed in the cylindrical brass body;
- two reflection sheeds installed in the centre of the pipe;
- two ultrasonic transducers at the upstream and downstream of the measurement channel (pipe section) to transmit and receive ultrasonic signals.

Calculator and indication device:

- the plastic housing of the calculator with indication device directly mounted on the flow sensor;
- PCBA board;
- the electronic scrolling LCD display (by button) with 9 digits and indication range of 999999,999 m³. The sub-multiples of a cubic meter are indicated on the LCD display with a box around three digits after the decimal point;
- two non-replaceable lithium batteries are used to supply metrology part and application functions (communication, detection, control, display..), lifetime 10 years, 9 Ah.
-

Non-essential parts of the water meter:

- internal valve for local control and remote control;
- motor for using of valve;
- strainer;
- the optical port for communication.

Metrological functions

- measuring, memorizing and displaying the volume of water passing through the water meter.



2.2 Operation and presentation of legal data

- the total measured volume (m³);
- flow rate (m³/h).

The following displays are available on the scroll display too:

- display test (an “eights” test);
- display test (a “blanks” test);
- open/close valve – valve status;
- forward consumption volume (m³);
- the last value for charge (m³) with date (MM-DD-YY);
- the total charge values (m³) reserved for prepay mode;
- real time (h/min/s) and date reserved for prepay mode (MM-DD-YY);
- test mode:
 - o forward accumulated consumption in the test mode;
 - o flow rate in the test mode;
 - o error code;
 - o tariff;
 - o software version and checksum;
 - o serial number;
 - o battery voltage and capacity;
 - o pressure value and water temperature.

3. Software specification

The legally relevant software version and checksum for water meters MA408:

Software versions	Checksum	Remarks
2014	D281BE55	

The software version and checksum can be checked using the scrolling display.

4. Accountable alarms

If a fault condition occurs and the measurement stops, follow the user manual issued by the manufacturer.



5. Technical and metrological data

Water meter type		MA408K		
Characteristics	Unit			
Nominal diameter DN	mm	DN15	DN20	DN25
Permanent flowrate Q_3	m ³ /h	2,5	4	6,3
Minimum flowrate Q_1	m ³ /h	0,00625	0,010	0,01575
Transitional flowrate Q_2	m ³ /h	0,010	0,016	0,0252
Overload flowrate Q_4	m ³ /h	3,125	5	7,875
Ratio Q_3/Q_1	R	400		
Ratio Q_2/Q_1	-	1,6		
Connection thread	mm	G ¾ B	G1 B	G1 ¼ B
Construction length L	mm	165	190/195/165	225
Installation orientation	-	H/V		
Water temperature range (temperature class)	°C	0,1 to 50 (T50)		
Maximum admissible pressure MAP	bar	16		
Pressure loss class Δp	bar -	0,40 Δp 40		
Maximum permissible error in upper flowrates range $Q_2 \leq Q \leq Q_4$	%	± 2 (at $\theta \leq 30^\circ\text{C}$) ± 3 (at $\theta > 30^\circ\text{C}$)		
Maximum permissible error in lower flowrates range $Q_1 \leq Q < Q_2$	%	± 5		
Capacity of calculator	m ³	999999,999		
Scale interval (normal resolution of the indicating device)	m ³	0,001		
Scale interval (high resolution)	m ³	0,0000001		
Accuracy class	-	2		
Mechanical class	-	M1		
Climatic class	°C	- 25 to + 55		
Electromagnetic class	-	E1/E2		
Climatic and mechanical environmental conditions (class) according to EN ISO 4064-1/OIML R 49-1	-	B/O		
Flow profile sensitivity class	-	U0D0		
Battery	-	non-replaceable li-battery 3,8 V life time 10 years		

6. Marking and inscriptions

The following data shall be marked on the water meter:

- a) unit of measurement (m³);
- b) flowrate Q_3 and ratio Q_3/Q_1 (R);
- c) type of water meter;



- d) manufacturers name or trademark;
- e) year of manufacture or the month and year of manufacture;
- f) serial number;
- g) direction of flow, by means of an arrow (shown on both sides of the body or on one side only provided the direction of flow arrow is easily visible under all circumstances);
- h) maximum admissible pressure (MAP);
- i) letter V or H, if the meter can only be operated in the vertical or horizontal position;
- j) temperature class (T);
- k) pressure loss class (Δp);
- l) installation sensitivity class where it different from U0/D0;
- m) for a non-replaceable battery, the latest date by which the meter shall be replaced;
- n) environmental classification (can be given on a document supplied separately);
- o) electromagnetic environmental class (can be given on a document supplied separately);
- p) type approval sign according to national regulations.

7. Security measures

The water meters MA408K shall be protected against unauthorized manipulation and opening by:

- two seals with the wire ensuring the connection of the upper cover (prevents access to the PCBA and software) with the lower part of the water meter (contains the body of the water meter) (Fig. 3).

8. Figures



Fig. 1: Illustrative views of the water meters type MA408K with valve

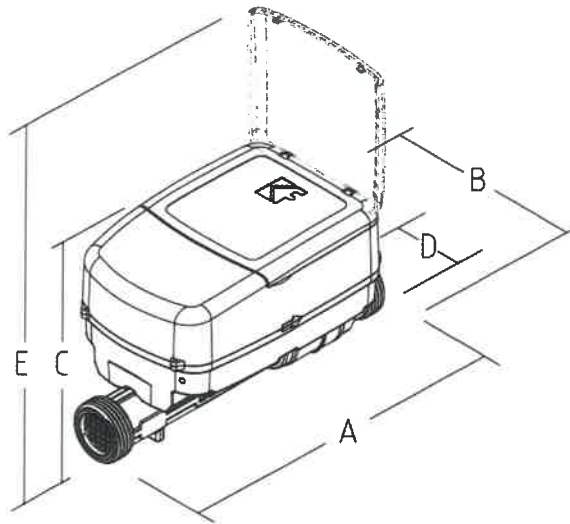

/	A	B	C	D	E
DN15	165	95,5	103,4	G 3/4	185,4
DN20	190	95,5	107,1	G1	189,1
DN25	260	95,5	109,9	G1 ^{1/4}	191,9

Fig. 2: Dimensions of water meter type MA408K

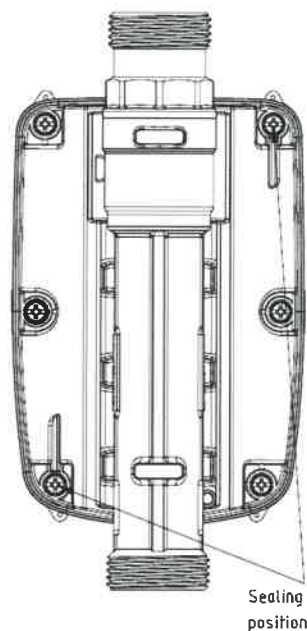
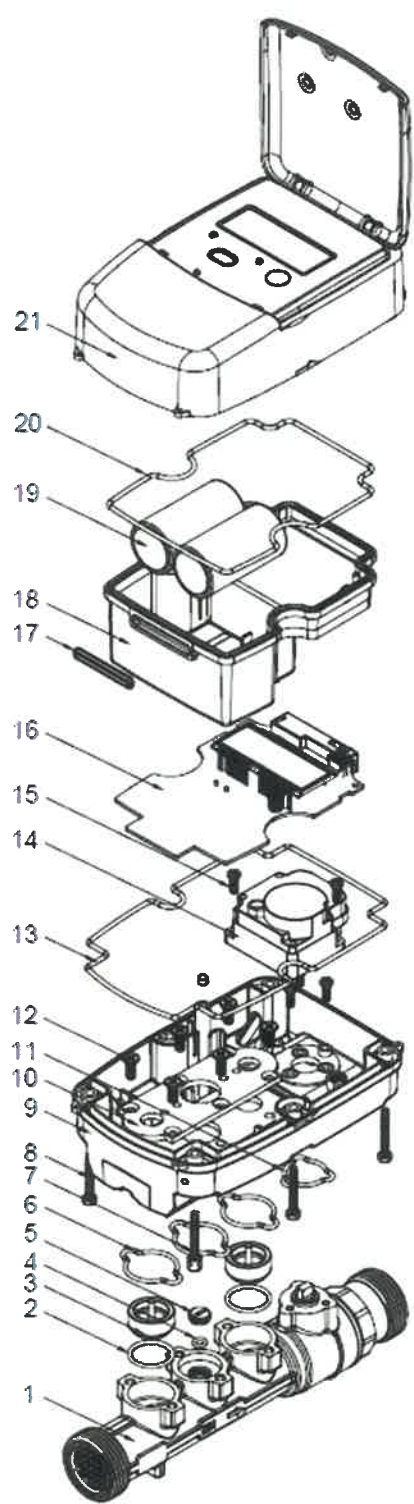

Fig. 3: Sealing of water meter type MA408K





21		Top cover	1
20		Top cover sealing	1
19		Battery	2
18		Inner box	1
17		PCB sealing	1
16		PCBA	1
15		Motor screw	2
14		Motor	1
13		Base cover sealing	1
12		Screw	6
11		Valve sealing	1
10		Pressing board	1
09		Base cover	1
08		Screw	4
07		Sealing screw	2
06		pipe sealing	3
05		pipe plug	1
04		O-ring of plug	1
03		Transducer	2
02		O-ring	2
01		Pipe section	1
No.	PART NUMBER	PART DESCRIPTION	QUANTITY

Fig: 4a: Exploded view of water meter MA408K



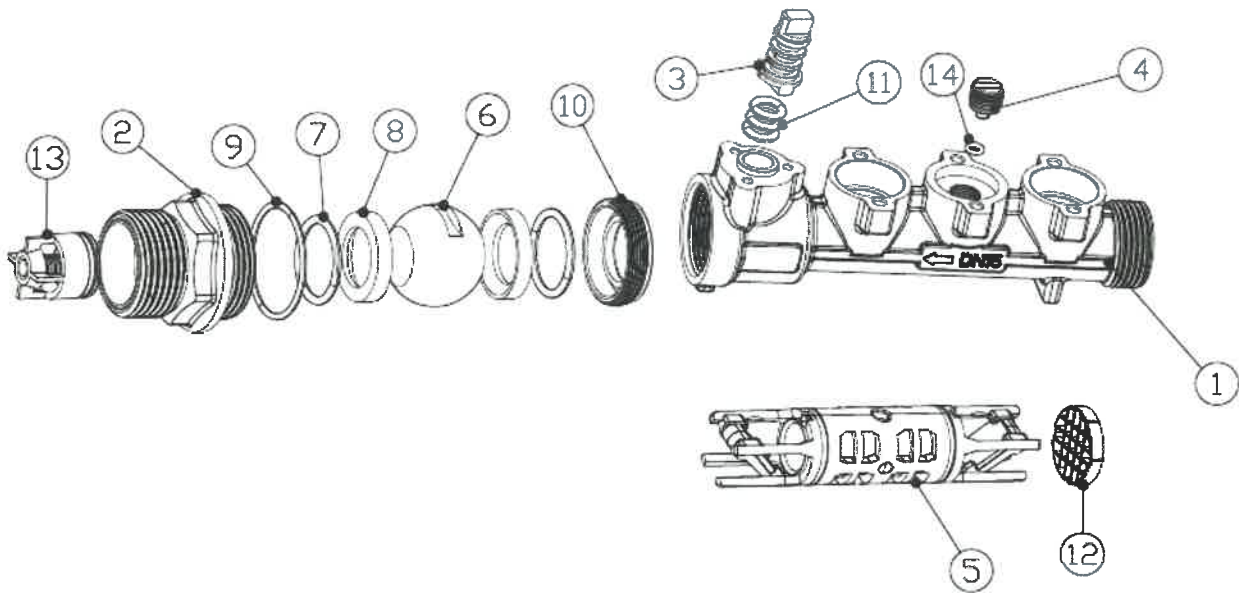

14	3007158	YH-OD6X1.6三元	O ring	EPDM	1
13	3008085	OV20	Check valve	POM	1
12	3008075	YH-GLW1SA01	Fliter	PPO	1
11	3007037	YH-OD9X1.9	O ring	EPDM	3
10	3009038	YH-LJHM2615	Retainer ring	S9-1	1
9	3007098	YH-OD26X1.5	O ring	EPDM	1
8	3014002	22X15.5X3.5	Valve seat	PTFE	2
7	3007043	YH-OD22X2	O ring	EPDM	2
6	3002001	YH-BQ251504	Valve	304	1
5	3009001	YH-DN15-CHZJ.1	Bracket	304+PPS	1
4	3009001	YH-DWXM10	Location pin	Hpb59-1	1
3	3005126	YH-DN15-CCFKA01.3	Valve stem	Hpb59-1	1
2	200203136	YH-DN15-CCFKA01.2	Valve control cap	Hpb59-1	1
1	200203168	YH-DN15-CCFKB01.1	Pipe	Hpb59-1	1

Fig: 4b: Assembly drawing body with valve of water meter MA408K
(DN15 sample)

