

INTERNATIONAL  
RECOMMENDATION

**OIML R 99-1 & 2**

Edition 2008 (E)

Reconfirmed in 2024

---

Instruments for measuring vehicle exhaust emissions

Part 1: Metrological and technical requirements

Part 2: Metrological controls and performance tests

Instruments de mesure des gaz d'échappement des véhicules

Partie 1: Exigences métrologiques et techniques

Partie 2: Contrôles métrologiques et essais de performance

---





## Contents

<b>FOREWORD</b> .....	<b>5</b>
<b>PART 1 - METROLOGICAL AND TECHNICAL REQUIREMENTS</b> .....	<b>6</b>
<b>0 Introduction</b> .....	<b>6</b>
<b>1 Scope</b> .....	<b>6</b>
<b>2 Normative references</b> .....	<b>6</b>
2.1 ISO Standards.....	7
2.2 IEC Standards.....	7
2.3 OIML Publications.....	8
2.4 Other Publications.....	8
<b>3 Terms and definitions</b> .....	<b>8</b>
<b>4 Description of the instrument</b> .....	<b>13</b>
<b>5 Metrological requirements</b> .....	<b>15</b>
5.1 Indication of the measured result .....	15
5.2 Measuring range.....	15
5.3 Resolution of indication .....	15
5.4 Durable recording of the measurement results .....	15
5.5 Maximum permissible errors.....	16
5.6 Influence quantities .....	17
5.7 Disturbances.....	18
5.8 Response time .....	19
5.9 Warm-up time .....	19
5.10 Propane/hexane equivalency factor.....	19
5.11 Lambda calculation .....	19
5.12 Stability with time or drift.....	20
5.13 Repeatability .....	20
<b>6 Technical requirements</b> .....	<b>20</b>
6.1 Construction .....	20
6.2 Adjustment facilities .....	22
6.3 Security of operation .....	22
<b>7 Inscriptions and operating instructions</b> .....	<b>24</b>
7.1 Inscriptions.....	24
7.2 Operating instructions .....	24
<b>PART 2 - METROLOGICAL CONTROLS AND TESTS</b> .....	<b>26</b>
<b>8 Metrological controls</b> .....	<b>26</b>
8.1 Type approval.....	26
8.2 Initial verification.....	27
8.3 Subsequent verification.....	28
<b>9 Performance tests for type approval</b> .....	<b>28</b>
9.1 Check of the error curve.....	28
9.2 Stability with time or drift.....	28
9.3 Repeatability .....	28
9.4 Effect of influence quantities .....	28
9.5 Disturbances.....	29
9.6 Tests for conformity to other technical and metrological requirements.....	29
9.7 Source of power for type evaluation .....	30

---

<b>ANNEX A DESCRIPTION OF PERFORMANCE TESTS FOR TYPE APPROVAL.....</b>	<b>31</b>
A.1 General.....	31
A.2 Error curve .....	31
A.3 Stability with time or drift.....	31
A.4 Repeatability .....	31
A.5 Dry heat.....	31
A.6 Cold.....	32
A.7 Damp heat, steady state.....	32
A.8 Atmospheric pressure.....	32
A.9 Voltage and frequency variation .....	33
A.10 Influence of other gas components on the measurand (cross sensitivity) .....	33
A.11 Mechanical shock and vibrations.....	34
A.12 AC mains voltage dips and short interruptions.....	34
A.13 Bursts (transients).....	35
A.14 Electrical transient conduction in case of road vehicle battery.....	35
A.15 Electrostatic discharges.....	36
A.16 Surges on signal, data, control and power lines.....	37
A.17 Radio frequency immunity .....	37
A.18 Mains frequency magnetic fields.....	38
A.19 Warm-up time.....	38
A.20 Response time.....	39
A.21 Low flow.....	39
A.22 Leakage.....	39
A.23 HC residue .....	39
A.24 Filter unit .....	40
A.25 Water separator.....	40
A.26 Propane/hexane equivalency factor .....	40
<b>ANNEX B DESIGNATION OF REFERENCE GASES AND THEIR COMPOSITION.....</b>	<b>42</b>
B.1 General requirements .....	42
B.2 Specifications and uncertainties of composition of the gas mixtures.....	42
B.3 Preparation of gases in special cases.....	42
B.4 Composition of the gas mixtures used for the tests.....	43
<b>ANNEX C PROCEDURE FOR ROUTINE TESTING.....</b>	<b>45</b>
<b>ANNEX D LAMBDA CALCULATION.....</b>	<b>46</b>
D.1 Introduction.....	46
D.2 Simplified lambda formula.....	46
D.3 Other formulae .....	46

---

## Foreword

The International Organization of Legal Metrology (OIML) is a worldwide, intergovernmental organization whose primary aim is to harmonize the regulations and metrological controls applied by the national metrological services, or related organizations, of its Member States. The main categories of OIML publications are:

- **International Recommendations (OIML R)**, which are model regulations that establish the metrological characteristics required of certain measuring instruments and which specify methods and equipment for checking their conformity; the OIML Member States shall implement these Recommendations to the greatest possible extent;
- **International Documents (OIML D)**, which are informative in nature and intended to improve the work of the metrological services;
- **International Basic Publications (OIML B)**, which define the operating rules of the various OIML structures and systems;
- **International Guides (OIML G)**, which are informative in nature and which are intended to give guidelines for the application of certain requirements to legal metrology.

OIML Draft Recommendations, Documents and Guides are developed by Technical Committees or Subcommittees which are formed by the Member States. Certain international and regional institutions also participate on a consultation basis. Cooperative agreements are established between the OIML and certain institutions, such as the Memorandum of Understanding signed between ISO and the OIML, with the objective of avoiding contradictory requirements; consequently, manufacturers and users of measuring instruments, test laboratories, etc. may simultaneously apply OIML publications and those of other institutions.

International Recommendations, Documents and Guides are published in French (F) and English (E) and are subject to periodic revision.

Additionally, the OIML participates in the publication of **Vocabularies (OIML V)** and periodically commissions legal metrology Experts to write **Expert Reports (OIML E)**. Expert Reports are intended to provide information and advice to metrological authorities, and are written solely from the viewpoint of their author, without the involvement of a Technical Committee or Subcommittee, nor that of the CIML. Thus they do not necessarily represent the views of the OIML.

This publication was jointly developed by OIML Technical Committee TC 16/SC 1 *Air pollution* and ISO Technical Committee TC 22/SC 5 *Engine tests*.

It is published by the OIML as OIML R 99-1 & 2 *Instruments for measuring vehicle exhaust emissions – Part 1: Metrological and technical requirements and Part 2: Metrological control and performance tests* and by ISO as ISO PAS 3930:2009 *Instruments for measuring vehicle exhaust emissions*.

The technical requirements set in OIML R 99-1 & 2, edition 2008 and ISO PAS 3930:2009 are identical.

This Publication - reference OIML R 99-1 & 2, edition 2008 (E) - was sanctioned by the International Conference of Legal Metrology in 2008. It supersedes OIML R 99 edition 2000 and its Amendment dated 2004.

OIML Publications may be downloaded from the OIML web site in the form of PDF files. Additional information on OIML Publications may be obtained from the Organization's headquarters:

Bureau International de Métrologie Légale  
11, rue Turgot - 75009 Paris - France  
Telephone: 33 (0)1 48 78 12 82  
Fax: 33 (0)1 42 82 17 27  
E-mail: [biml@oiml.org](mailto:biml@oiml.org)  
Internet: [www.oiml.org](http://www.oiml.org)

# Instruments for measuring vehicle exhaust emissions

## Part 1 - Metrological and technical requirements

### 0 Introduction

The joint development of OIML R 99-1 & 2:2008 and ISO PAS 3930:2009 consists of a revision of ISO 3930 / OIML R 99, edition 2000 and its amendment (2004). In addition to a number of editorial changes, the main changes in this edition, from the previous edition, are:

- The Recommendation has been split into two Parts:
  - Part 1 *Metrological and technical requirements*; and
  - Part 2 *Metrological control and performance tests*.
- Class II and analog instruments are no longer addressed. For instruments which are still in use, national authorities can decide on national transitional arrangements for Class II and/or analog instruments, based on the previous edition (2000).
- An accuracy class 00 has been added, defining more stringent accuracy requirements for CO, CO<sub>2</sub> and HC.
- Requirements and tests relating to electromagnetic compatibility (EMC) have been added/updated, taking into account the revisions of the appropriate ISO/IEC Standards.
- Requirements have been added for means of durable recording such as printing devices, for software and for instruments powered by a battery.

Part 3 *Report Format* is published separately by the OIML under the reference OIML R 99-3:2008.

### 1 Scope

This International Recommendation specifies the metrological and technical requirements and tests for digital measuring instruments (hereafter termed “instrument(s)”) that serve to determine the volume fractions of certain components of the exhaust gases emanating from motor vehicles. The conditions with which such instruments shall comply in order to meet any OIML performance requirements are also established.

It is applicable to instruments, particularly those used according to the procedure defined in ISO 3929, intended for the inspection and maintenance of in-use motor vehicles with spark ignition engines. These instruments are used to determine the volume fraction of one or more of the following exhaust gas components:

- carbon monoxide (CO);
- carbon dioxide (CO<sub>2</sub>);
- hydrocarbons (HC, in terms of n-hexane); and
- oxygen (O<sub>2</sub>)

at the moisture level of the sample as analyzed.

In addition to the measurement of these components, the instruments can be provided with a facility to determine the value of “lambda” (see 3.32).

This Recommendation applies to instruments whose principle of detection is based on infrared absorption in gases for CO, CO<sub>2</sub> and HC.

Oxygen is generally measured with a fuel cell. It is not intended, however, to exclude any other types of instruments that, although based on other principles of detection, meet the specified metrological and technical requirements and satisfy the associated tests. Three accuracy classes of the instruments, Class 00, Class 0, and Class I are included.

This Recommendation does not apply to equipment for on-board diagnostics incorporated in motor vehicles.

### 2 Normative references

The following normative documents contain provisions which, through reference in this text, constitute provisions of this Recommendation.

Subsequent amendments to, or revisions of dated references do not apply. However, parties to agreements based on this Recommendation are encouraged to investigate the possibility of applying the most recent editions of the normative documents indicated below. For undated references, the latest edition of the normative document referred to applies.

Members of ISO, IEC, and the OIML maintain registers of currently valid International Standards. The actual status of the Standards referred to can also be found on the Internet:

- IEC Publications: <http://www.iec.ch>
- ISO Publications: <http://www.iso.org>
- OIML Publications: <http://www.oiml.org> (with free download of PDF files).

## 2.1 ISO Standards

ISO 3929 (2003), *Road vehicles — Measurement methods for exhaust gas emissions during inspection or maintenance*

ISO 6142 (2001), *Gas analysis — Preparation of calibration gas mixtures — Gravimetric method*

ISO 6145 (all parts), *Gas analysis — Preparation of calibration gas mixtures — Dynamic volumetric methods*

ISO 7504 (2001), *Gas analysis — Vocabulary*

ISO 7637-1 (2002), *Road vehicles — Electrical disturbance from conducting and coupling — Part 1: Definitions and general considerations*

ISO 7637-2 (2004) *Road vehicles — electrical disturbance by conducting and coupling – Part 2: Electrical transient conduction along supply lines only*

ISO 7637-3 (1995) with correction 1 (1995) *Road vehicles — Electrical disturbance by conducting and coupling — Part 3: Passenger cars and light commercial vehicles with nominal 12 V supply voltage and commercial vehicles with 24 V supply voltage — Electrical transient transmission by capacitive and inductive coupling via lines other than supply lines*

ISO 14912 (2003) with correction 1 (2006), *Gas analysis — conversion of gas mixture composition data*

## 2.2 IEC Standards

IEC 60068-2-1 (1990), *Environmental testing — Part 2: Tests — Test A: Cold*, with amendments 1 (1993) and 2 (1994)

IEC 60068-2-2 (1974), *Environmental testing — Part 2: Tests — Test B: Dry heat*, with Amendments 1 (1993) and 2 (1994)

IEC 60068-2-78 (2001), *Environmental testing — Part 2: Tests — Test Cab: Damp heat, steady state*

IEC 60068-2-31 (1969), *Environmental testing — Part 2: Tests — Test Ec: Drop and topple, primarily for equipment type specimens*, with Amendment 1 (1982)

IEC 60068-2-64 (1993), *Environmental testing — Part 2: Test methods — Test Fh: Vibration, broad band random (digital control) and guidance*, with Correction 1 (1993)

IEC 60068-3-1 (1974), *Environmental testing — Part 3: Background information — Section 1: Cold and dry heat tests*, with Supplement 1 (1978)

IEC 60068-3-4 (2001), *Environmental testing — Part 3-4: Supporting documentation and guidance - Damp heat tests*

IEC/TR 61000-2-1 (1990-05), *Electromagnetic compatibility (EMC) — Part 2: Environment— Section 1: Description of the environment - Electromagnetic environment for low-frequency conducted disturbances and signaling in public power supply systems*

IEC 61000-4-2 (1995), *Electromagnetic compatibility (EMC) — Part 4: Testing and measurement techniques — Section 2: Electrostatic discharge immunity test*, with Amendments 1 (1998) and 2 (2000) — (Consolidated edition 2001)

IEC 61000-4-3 (2006), *Electromagnetic compatibility (EMC) — Part 4: Testing and measurement techniques — Section 3: Radiated, radio-frequency, electromagnetic field immunity test*

IEC 61000-4-4 (2004), *Electromagnetic compatibility (EMC) — Part 4: Testing and measurement techniques — Section 4: Electrical fast transient/burst immunity test*

IEC 61000-4-5 (2005), *Electromagnetic compatibility (EMC) — Part 4: Testing and measurement techniques — Section 5: Surge immunity test*

IEC 61000-4-6 (2003), *Electromagnetic compatibility (EMC) — Part 4: Testing and measurement techniques — Section 6: Immunity to conducted disturbances, induced by radio-frequency fields*, with Amendment 1 (2004) and Amendment 2 (2006) - (Consolidated edition 2006)

IEC 61000-4-8 (1993) *Electromagnetic compatibility (EMC) — Part 4: Testing and measurement techniques — Section 8: Power frequency magnetic field immunity test*, with Amendment 1 (2000) — (Consolidated edition 2001).

### **2.3 OIML Publications**

OIML V 1 (2000) *International Vocabulary of Terms in Legal Metrology (VIML)*

OIML D 11 (2004) *General requirements for electronic measuring instruments*

### **2.4 Other Publications**

*International Vocabulary of Metrology-- Basic and general concepts and associated terms (VIM)*, Third edition (2007/2008): Joint publication by the BIPM, IEC, IFCC, ISO, IUPAC, IUPAP, and OIML.

*Guide to the expression of uncertainty in measurement (GUM)*, (1995): Joint publication by the BIPM, IEC, IFCC, ISO, IUPAC, IUPAP, and OIML

## **3 Terms and definitions**

For the purposes of this Recommendation, the following terms and definitions apply.

### **3.1 sampling probe**

tube that is introduced into the exhaust tail pipe of a vehicle to take gas samples

### **3.2 water separator**

device that removes water from the exhaust gas sample to a level that prevents condensation within the gas handling system downstream from its location

### **3.3 filter unit**

device that removes particles from the exhaust gas sample

### **3.4 gas handling system**

all instrument components, from the sampling probe to the gas sample outlet, through which the exhaust gas sample is conveyed by the pump

### **3.5 adjustment (of a measuring instrument)**

set of operations carried out on a measuring system so that it provides prescribed indications corresponding to given values of a quantity to be measured (VIM:2007, 3.11)

### **3.6 user adjustment (of a measuring instrument)**

adjustment employing only the means at the disposal of the user



**3.7 manual adjustment facility**

facility allowing the adjustment of the instrument by the user

**3.8 semi-automatic adjustment facility**

facility allowing the user to initiate an adjustment of the instrument without having the possibility of influencing its magnitude, whether or not the adjustment is automatically required

*Note:* For those instruments that require the values of the volume fractions of the reference gas to be entered manually, the facility is considered to be semi-automatic.

**3.9 automatic adjustment facility**

facility performing the adjustment of the instrument as programmed without the intervention of the user, to initiate the adjustment or its magnitude

**3.10 zero-setting facility**

facility to set the indication of the instrument to zero

**3.11 reference gas adjustment facility**

facility to adjust the instrument to the value of a reference gas

**3.12 internal adjustment facility**

facility to adjust the instrument to a designated value without the use of an external reference gas

**3.13 warm-up time**

elapsed time between the moment power is applied to an instrument and the moment at which the instrument is capable of complying with the metrological requirements

**3.14 step response time**

duration between the instant when an input quantity value of a measuring instrument or measuring system is subjected to an abrupt change between two specified constant quantity values and the instant when a corresponding indication settles within specified limits around its final steady value (referred to as “response time” in this Recommendation) (VIM:2007, 4.23)

**3.15 conventional true quantity value**

quantity value attributed by agreement to a quantity for a given purpose (VIM:2007, 2.12)

**3.16 reference (quantity) value**

quantity value used as a basis for comparison with values of quantities of the same kind (VIM:2007, 5.18)

**3.17 error (of measurement)**

measured quantity value minus a reference quantity value (VIM:2007, 2.16)

**3.18 intrinsic error**

error of a measuring instrument determined under reference conditions

**3.19 relative error**

error of measurement divided by the conventional true quantity value of the measurand

**3.20 fault**

difference between the error of indication and the intrinsic error of the instrument (OIML D 11:2004, 3.9)

**3.21 significant fault**

fault which has a magnitude greater than the magnitude of the maximum permissible error on initial verification

*Notes:* 1 The following faults are considered to be not significant:

- a) Fault arising from simultaneous and mutually independent causes in the instrument itself or in its checking facilities;
- b) Faults implying the impossibility to perform any measurement;
- c) Transitory faults being momentary variations in the indication, which cannot be interpreted, recorded or transmitted as a measurement result; and
- d) Faults giving rise to variations in the measurement results that are so large as to be noticed by all those interested in the measurement result.

2 Adapted from OIML D 11:2004, 3.10.

**3.22 expanded (measurement) uncertainty**

product of a combined standard measurement uncertainty and a factor larger than the number one (VIM:2007, 2.35)

**3.23 coverage factor**

number larger than one by which a combined standard measurement uncertainty is multiplied to obtain an expanded measurement uncertainty (VIM:2007, 2.38)

*Note:* A coverage factor is usually symbolized by the letter *k* (see also GUM, 2.3.6).

**3.24 influence quantity**

quantity that, in a direct measurement, does not affect the quantity that is actually measured, but affects the relation between the indication and the measurement result (VIM:2007, 2.52)

**3.25 rated operating conditions**

operating condition that must be fulfilled during measurement in order that a measuring instrument or measuring system perform as designed (VIM:2007, 4.9)

**3.26 influence factor**

influence quantity having a value within the rated operating conditions of the instrument

*Note:* Adapted from OIML D 11:2004, 3.13.1.

**3.27 disturbance**

influence quantity having a value within the limits specified in this Recommendation but outside the rated operating conditions of the instrument

*Note:* Adapted from OIML D 11:2004, 3.13.2.

**3.28 reference condition**

operating condition prescribed for evaluating the performance of a measuring instrument or measuring system or for comparison of measurement results (VIM:2007, 4.11)

**3.29 checking facility**

facility that is incorporated in the instrument and that enables significant faults to be detected and acted upon

- Notes:*
- 1 “Acted upon” means any adequate response by the instrument (luminous or acoustic signal, blocking of process, etc.);
  - 2 Adapted from OIML D 11:2004, 3.18.

**3.30 automatic checking facility**

checking facility operating without the intervention of the user

*Note:* Adapted from OIML D 11:2004, 3.18.1.

**3.30.1 permanent automatic checking facility (type P)**

automatic checking facility operating during each measurement cycle

*Note:* Adapted from OIML D 11:2004, 3.18.1.1

**3.30.2 intermittent automatic checking facility (type I)**

automatic checking facility operating at certain time intervals or per fixed number of measurement cycles

*Note:* Adapted from OIML D 11:2004, 3.18.1.2.

**3.31 legally relevant software**

any part of the software, including stored parameters, which has an influence on the calculated, displayed, transmitted, or stored measurement result.

**3.32 test**

series of operations intended to verify the compliance of the equipment under test (EUT) with specified requirements (OIML D 11:2004, 3.20)

**3.33 lambda**

dimensionless value representative of the burning efficiency of an engine in terms of the air/fuel ratio in the exhaust gases and determined with a referenced standardized formula

**3.34 reference gas**

gas mixture of sufficient stability and homogeneity whose composition is properly established for use in various performance tests

- Notes:*
- 1 Adapted from ISO 7504, 4.1 (calibration gas mixture) and 4.1.1 (reference gas mixture) and “VIM”, 5.13 (reference material) and 5.14 (certified reference material);
  - 2 In the referent ISO Standards, the expression “calibration gas” is generally used;
  - 3 See also Annex B.

**3.35 modulus (of a number) absolute value**

value of the number without regard to its sign

**3.36 hand-held instrument**

type of instrument that is designed for hand-held transportation with its standard accessories by one person, and that rests on a suitable surface during use

**3.37 mains power**

primary external source of electrical power for the instrument, including all sub assemblies. (Examples: public power network (AC or DC), generator, external battery or other DC supply systems) (adapted from OIML D 11:2004, 3.21)

**3.38 power converter (power supply device)**

sub assembly converting the voltage from the mains power to a voltage suitable for other sub assemblies. (OIML D 11:2004, 3.22)

**3.39 back-up battery**

battery that is intended to power specific functions of an instrument in the absence of the primary power supply (for example: to preserve stored data). (OIML D 11:2004, 3.24)

**3.40 motor vehicle**

road vehicle, powered by a built-in engine, which is not rail borne, and which is normally used for applications such as:

- carrying persons and/or goods;
- towing vehicles used for the carriage of persons and/or goods.

**3.41 Abbreviations**

AC	Alternating Current
AM	Amplitude Modulation
ASD	Acceleration Spectral Density
DC	Direct Current
EM	Electro Magnetic
EMC	Electro Magnetic Compatibility
e.m.f.	electromotive force
ESD	Electrostatic Discharge
EUT	Equipment Under Test
IEC	International Electrotechnical Commission
ISO	International Organization for Standardization
N.A.	Not Applicable
OIML	International Organization of Legal Metrology
PEF	Propane/hexane Equivalency Factor
RMS	Root Mean Square

## 4 Description of the instrument

**4.1** Generally, the instrument provides a means for sampling and then measuring the exhaust gases emitted from the tail pipe of a motor vehicle. A pump provides the means for conveying the gas sample through a gas handling system. One or more detection devices, incorporated in the gas handling system, analyze the sample and provide signals related to the volume fractions of gas components of interest, namely CO, CO<sub>2</sub>, HC and O<sub>2</sub>. The detector signals are then electrically processed to display and possibly record the results of a measurement in volume fractions of the gas components together with other important related information such as a lambda value calculation.

**4.2** Acceptable overall performance of the instrument is dependent upon its various components for the associated characteristics. An example of an instrument using a reference gas for adjustment is shown in Figure 1.

**4.3** The major instrument components are as follows:

- a sampling probe introduced in the tail pipe of an operating motor vehicle to collect the exhaust gas sample;
- a hose with associated tubing connected to the probe to provide a path for the gas sample to enter, pass through and exit the instrument;
- a pump to convey the gases through the instrument;
- a water separator to prevent water condensation from forming in the instrument;
- a filter to remove particles that could cause contamination of various sensitive parts of the instrument;
- ports downstream from the water separator and filter to introduce ambient air and reference gas when required by the technology used;
- detection devices to measure the volume fractions of the gas sample;
- a data system to process the signal including an indicating device to display the results of a measurement; and
- a control facility to initiate and check instrument operations and a manual, semi-automatic, or automatic adjustment facility to set instrument operating parameters within prescribed limits.

**4.4** The instrument can be provided with ancillary devices for measuring the oil temperature and/or the engine speed. This Recommendation, however, does not apply to these devices.

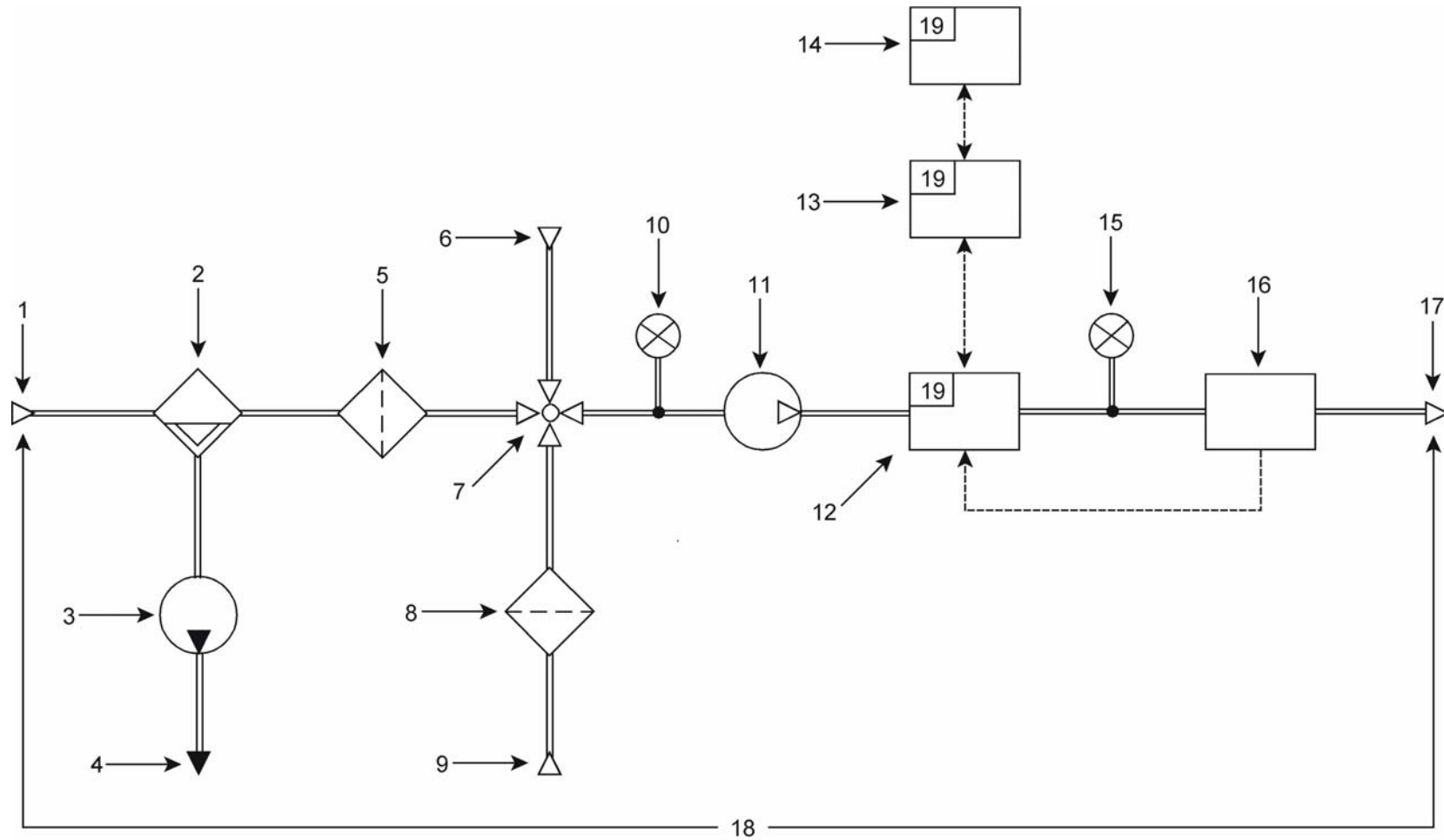

**Figure 1 — Diagrammatic illustration of an instrument for measuring vehicle exhaust emissions (references in parenthesis are to the relevant sub-clauses in the text)**

**Key**

- |                           |   |   |                                |
|---------------------------|---|---|--------------------------------|
| 1 Sampling probe (6.1.2)  | 6 Reference gas input (6.1.5)           | 11 Gas pump (6.1.6)                                 | 16 O <sub>2</sub> sensor       |
| 2 Water separator (6.1.4) | 7 Electro valve                         | 12 Measurement bench for CO, CO <sub>2</sub> and HC | 17 Gas output                  |
| 3 Water pump              | 8 Charcoal filter (6.1.5)               | 13 Indicating device (6.2 and 6.3)                  | 18 Gas handling system (6.1.8) |
| 4 Water output            | 9 Gas input for zero-setting (6.1.5)    | 14 Interfaces (6.1.9)                               | 19 Software                    |
| 5 Gas filter (6.1.3)      | 10 Differential pressure sensor (6.1.7) | 15 Atmospheric pressure sensor                      |                                |

## 5 Metrological requirements

### 5.1 Indication of the measurement result

The volume fractions of the gas components shall be expressed as a percentage (% vol) for CO, CO<sub>2</sub> and O<sub>2</sub> and in parts per million (ppm vol) for HC. The inscriptions for these units shall be assigned unambiguously to the indication, for example “% vol CO”, “% vol CO<sub>2</sub>”, “% vol O<sub>2</sub>” and “ppm vol HC”.

It shall be possible to display the indication of the measurement results of the different components simultaneously.

*Note:* Historically, the units of volume fraction have been used for field inspection. However, gas mixtures can generally be manufactured in molar fractions to more accurate standards. Assuming the gas mixtures obey the ideal gas law, molar fractions are considered to be equal to volume fractions in this Recommendation. Accurate conversion from mole fraction to volume fraction is prescribed in ISO 14912.

### 5.2 Measuring range

The minimum indicating ranges that may be subdivided shall be as given in Table 1.

**Table 1**

Measuring ranges			
CO % vol	CO <sub>2</sub> % vol	O <sub>2</sub> % vol	HC ppm vol
0 to 5	0 to 16	0 to 21	0 to 2 000

### 5.3 Resolution of indication

As indicated in the Scope, this Recommendation only refers to digital indicating instruments. Digital figures shall be at least 5 mm high. The least significant figure of the display shall provide a resolution equal to or higher by one order of magnitude than the values given in Table 2.

**Table 2**

Minimum resolutions				
CO % vol	CO <sub>2</sub> % vol	O <sub>2</sub> % vol		HC ppm vol
		≤ 4 % vol	> 4 % vol	
0.01	0.1	0.01	0.1	1

The lambda value, if required, shall be displayed digitally to four figures and shall be identified by an appropriate symbol or sign (e.g. lambda or  $\lambda = x.xxx$ ). The resolution shall be 0.001.

### 5.4 Durable recording of the measurement results

The measurement results shall be recorded by a durable means, accompanied by information to identify the particular measurement.

For a printer, the following requirements apply:

- Printing shall be clear and permanent for the intended use;
- The resolution of the printed data shall be the same as the resolution of the indication;
- Printed figures shall be at least 2 mm high;
- If printing takes place, the name or the symbol of the unit of measurement shall be either to the right of the value or above a column of values;
- In case of an external printing device, the data transmission shall comply with 6.1.9.

## 5.5 Maximum permissible errors

### 5.5.1 Maximum permissible intrinsic errors

The maximum permissible errors given in Table 3 shall apply for an instrument under the reference conditions specified in 5.6.1.

**Table 3**

Class	Type of error	Maximum permissible errors <sup>a</sup>			
		CO	CO <sub>2</sub>	O <sub>2</sub>	HC
00	Absolute	± 0.02 % vol	± 0.3 % vol	± 0.1 % vol	± 4 ppm vol
	Relative	± 3 %	± 3 %	± 3 %	± 3 %
0	Absolute	± 0.03 % vol	± 0.4 % vol	± 0.1 % vol	± 10 ppm vol
	Relative	± 3 %	± 4 %	± 3 %	± 5 %
I	Absolute	± 0.06 % vol	± 0.4 % vol	± 0.1 % vol	± 12 ppm vol
	Relative	± 3 %	± 4 %	± 3 %	± 5 %

<sup>a</sup> Absolute or relative, whichever is greater.

The type of instrument is presumed to comply with this requirement if it passes test A.2 in Part 2 of this Recommendation.

### 5.5.2 Maximum permissible errors on initial verification

The maximum permissible errors given in Table 4 shall apply for instruments at type approval and at initial verification under the rated operating conditions specified in 5.6.2.

**Table 4**

Class	Type of error	Maximum permissible errors <sup>a</sup>			
		CO	CO <sub>2</sub>	O <sub>2</sub>	HC
00	Absolute	± 0.02 % vol	± 0.3 % vol	± 0.1 % vol	± 4 ppm vol
	Relative	± 5 %	± 5 %	± 5 %	± 5 %
0	Absolute	± 0.03 % vol	± 0.5 % vol	± 0.1 % vol	± 10 ppm vol
	Relative	± 5 %	± 5 %	± 5 %	± 5 %
I	Absolute	± 0.06 % vol	± 0.5 % vol	± 0.1 % vol	± 12 ppm vol
	Relative	± 5 %	± 5 %	± 5 %	± 5 %

<sup>a</sup> Absolute or relative, whichever is greater.

### 5.5.3 Maximum permissible errors on subsequent verification

The maximum permissible errors on subsequent verification shall be in accordance with Table 4.



## 5.6 Influence quantities

### 5.6.1 Reference conditions

- |    |  |  |
|----|--|--|
| a) | ambient temperature                    | 20 °C ± 2 °C;                                  |
| b) | relative humidity                      | 60 % ± 10 % (see note);                        |
| c) | atmospheric pressure                   | stable ambient;                                |
| d) | mains voltage                          | nominal voltage ± 2 %;                         |
| e) | mains frequency                        | nominal frequency ± 1 %;                       |
| f) | presence of influencing gas components | none except the measurands in N <sub>2</sub> ; |
| g) | vibration                              | none / negligible;                             |
| h) | voltage of battery                     | nominal voltage of the battery.                |

*Note:* In case of infrared technology, a relative humidity range from 30 % to 60 % is acceptable.

### 5.6.2 Rated operating conditions

- |    |                                 |  |
|----|---------------------------------|--|
| a) | ambient temperature             | + 5 °C to + 40 °C <sup>(1)</sup> ;   |
| b) | relative humidity               | up to 85 %, no condensation;   |
| c) | atmospheric pressure            | 860 hPa to 1 060 hPa <sup>(2)</sup> ;  |
| d) | mains voltage                   | – 15 % to + 10 % of the nominal voltage;   |
| e) | mains frequency                 | ± 2 % of the nominal frequency;  |
| f) | voltage of road vehicle battery | 12 V battery: 9 V to 16 V;<br>24 V battery: 16 V to 32 V;  |
| g) | voltage of internal battery     | low voltage as specified by the manufacturer, up to the voltage of a new or fully charged battery of the specified type. |
- <sup>(1)</sup> Unless otherwise specified by the manufacturer, these are the standardized ranges for the ambient temperature. The manufacturer, however, can specify different ranges under the following conditions:  
- the lower temperature shall be 5 °C;  
- the higher temperature shall be either 40 °C or 55 °C.
- <sup>(2)</sup> Unless otherwise specified by the manufacturer, this is the standardized range for the atmospheric pressure. The manufacturer, however, can specify an extended range for atmospheric pressure, but this shall include the standardized range.

The type of instrument is presumed to comply with the requirements 5.6.2 if it passes the following tests in Part 2 of this Recommendation:

Requirement	Test (in Part 2)
5.6.2, a)	A.5 + A.6
5.6.2, b)	A.7
5.6.2, c)	A.8
5.6.2, d) and e)	A.9.1
5.6.2, f)	A.9.2
5.6.2, g)	A.9.3

### 5.6.3 Influence of other gas components on the measurand (cross sensitivity)

The design of the instrument shall be such that measurements do not vary by more than half the modulus of the maximum permissible error on initial verification when gases other than the measurand are present in the following maximum volume fractions:

- 16 % vol CO<sub>2</sub>;
- 6 % vol CO;
- 10 % vol O<sub>2</sub>;

- 5 % vol H<sub>2</sub>;
- 0.3 % vol NO;
- 2 000 ppm vol HC (as n-hexane); and
- water vapor up to saturation.

However, the presence of H<sub>2</sub> is not necessary for testing the O<sub>2</sub> channel and the presence of O<sub>2</sub> and H<sub>2</sub> is not necessary in the case of infrared technology.

The type of instrument is presumed to comply with this requirement if it passes test A.10 in Part 2 of this Recommendation.

## 5.7 Disturbances

Significant faults as defined in 3.21 shall either not occur or shall be detected and acted upon by means of checking facilities in case of the following disturbances:

a)	Mechanical shock	1 fall of 25 mm on each bottom edge
b)	Vibration	10 Hz to 150 Hz, 1.6 ms <sup>-2</sup> , 0.05 m <sup>2</sup> s <sup>-3</sup> , -3 dB/octave
c)	AC mains voltage dips and short interruptions	0.5 cycles            reduction to 0 %
		1 cycle                reduction to 0 %
		25/30 <sup>(1)</sup> cycles        reduction to 70 %
		250/300 <sup>(1)</sup> cycles     reduction to 0 %
d)	Bursts (transients) on mains lines	Amplitude 1 kV Repetition rate 5 kHz
e)	Bursts (transients) on signal, data and control lines	Amplitude 0.5 kV Repetition rate 5 kHz
f)	For instruments powered by a road vehicle battery:	
	electrical transient conduction along supply lines of 12 V or 24 V vehicle batteries	Pulses 2a, 3a, 3b, and 4, severity level IV according to ISO 7637-2
	transients from DC motors acting as generators after the ignition is switched off	Test pulse 2b, severity level IV according to ISO 7637-2
	electrical transient conduction via lines other than supply lines for 12 V or 24 V vehicle batteries	Pulses a and b, severity level IV according to ISO 7637-3
g)	Electrostatic discharge	6 kV contact discharge 8 kV air discharge
h)	Radiated, radio-frequency, electromagnetic fields	up to 2 GHz, 10 V/m
i)	Conducted radio-frequency fields	up to 80 MHz, 10 V (e.m.f.)
j)	Power frequency magnetic fields	up to 30 A/m
k)	Surges	
	line to line on mains power, and unbalanced signal data and control lines	1.0 kV
	line to earth on mains power, signal data and control lines	2.0 kV

<sup>(1)</sup> For 50 Hz/ 60 Hz respectively

The type of instrument is presumed to comply with the above mentioned requirements if it passes the following examinations and tests in Part 2 of this Recommendation:

Requirement	Test (in Part 2)
5.7, a)	A.11.1
5.7, b)	A.11.2
5.7, c)	A.12
5.7, d) + e)	A.13
5.7, f)	A.14
5.7, g)	A.15
5.7, h)	A.17.1
5.7, i)	A.17.2
5.7, j)	A.18
5.7, k)	A.16

### 5.8 Response time

For measuring CO, CO<sub>2</sub> and HC, the instrument including the specified gas handling system shall indicate 95 % of the final value (as determined with reference gases) within 15 s after changing from a gas with zero content.

For measuring O<sub>2</sub>, the instrument shall indicate a value differing less than 0.1 % vol of the final value within 60 s after changing from air to oxygen-free reference gas.

The type of instrument is presumed to comply with this requirement if it passes test A.20 in Part 2 of this Recommendation.

### 5.9 Warm-up time

After the warm-up time, the instrument shall meet the metrological requirements stated in this Recommendation.

The instrument shall prevent an indication of measured gas volume fractions during the warm-up time.

The type of instrument is presumed to comply with this requirement if it passes test A.19 in Part 2 of this Recommendation.

### 5.10 Propane/hexane equivalency factor

The content of hydrocarbons shall be expressed in ppm vol n-hexane (C<sub>6</sub>H<sub>14</sub>) equivalent. The adjustment may be carried out using propane (C<sub>3</sub>H<sub>8</sub>). Therefore, a conversion factor referred to as “C<sub>3</sub> /C<sub>6</sub> equivalence factor”, or PEF, shall be provided by the manufacturer for each individual instrument to three significant figures (see also 7.1.2).

For instruments with one single conversion factor, the measuring values obtained when tested with n-hexane shall not differ by more than the applicable maximum permissible error from the curve established with propane.

For instruments capable of displaying an array of conversion factors, the measuring values obtained when tested with n-hexane shall not differ by more than half the value of the applicable maximum permissible error from the curve established with propane.

The type of instrument is presumed to comply with this requirement if it passes test A.26 in Part 2 of this Recommendation.

*Note:* The value for this factor is usually between 0.490 and 0.540.

### 5.11 Lambda calculation

Instruments equipped with a lambda indication shall carry out the appropriate calculation with a suitable formula. For lambda values between 0.8 and 1.2, the maximum permissible error in the calculation with respect to the resolution and the application of the chosen formula shall not exceed 0.3 %. For this purpose, the conventional true quantity value is calculated according to the formula specified in Annex D.

*Note:* The choice of a specific formula with its parameters may be subject to national regulation; see Annex D for more information.

### **5.12 Stability with time or drift**

When used in accordance with the manufacturer's operating instructions, the measurements made by the instrument, under stable environmental conditions and after adjustment using a reference gas or the internal adjustment facility, shall remain within the maximum permissible errors on initial verification for at least 4 h without the need for reference gas or internal readjustments by the user. If the instrument is equipped with a means for drift compensation, such as automatic zero or automatic internal adjustment, the action of these adjustments shall not produce an indication that can be confused with a measurement of an external gas.

The type of instrument is presumed to comply with this requirement if it passes test A.3 in Part 2 of this Recommendation.

### **5.13 Repeatability**

For 20 consecutive measurements of the same reference gas mixture carried out by the same person with the same instrument within relatively short time intervals, the experimental standard deviation of the 20 results shall not be greater than one third of the modulus of the maximum permissible error on initial verification taken from 5.5.2 for the relevant gas mixture.

The type of instrument is presumed to comply with this requirement if it passes test A.4 in Part 2 of this Recommendation.

## **6 Technical requirements**

### **6.1 Construction**

**6.1.1** All components of the gas handling system shall be made of corrosion-resistant material. The material of the sampling probe shall withstand the exhaust gas temperature. The materials used shall not influence the composition of the gas sample.

**6.1.2** The sampling probe shall be so designed that it can be inserted at least 30 cm into the exhaust tail pipe of the vehicle and be held in place by a retaining device regardless of the depth of insertion.

**6.1.3.1** The gas handling system shall contain a filter unit with reusable or replaceable elements capable of removing particles larger than 5 µm in diameter. It shall be possible to observe the degree of a filter's contamination without its removal, and it shall also be possible to replace, when necessary, this filter easily without special tools.

**6.1.3.2** It shall be possible to use the instrument for a period of at least 0.5 h with exhaust gas from a specially adjusted test engine having an HC fraction of approximately 800 ppm.

The type of instrument is presumed to comply with this requirement if it passes test A.24 in Part 2 of this Recommendation.

**6.1.4.1** The gas handling system shall contain a water separator that prevents water condensation from forming in measuring components.

The type of instrument is presumed to comply with this requirement if it passes test A.25 in Part 2 of this Recommendation.

**6.1.4.2** In the case of saturation of the water separator, it shall either empty automatically or the measurement operation shall be automatically stopped.

**6.1.5** In addition to the probe, instruments with an HC channel shall have a port for drawing in ambient air or other gas without hydrocarbons, to provide a reference for zero-setting of the instrument. If used, ambient air shall pass through a charcoal filter or equivalent system. Instruments without an HC channel may also be equipped with this additional port.

Oxygen measuring cells cannot use ambient air for zero-setting; if zero-setting is required an oxygen-free gas should be used.

Another additional port may be added in the gas handling system for introducing reference gas(es).

Both ports shall be located downstream of the water separator and filter unit in order to minimize potential contamination of the gases introduced. A means shall be provided to maintain the same pressure within the detector during zero-setting, gas adjustment, and sampling.

**6.1.6** The pump conveying the exhaust gas shall be mounted so that its vibrations do not affect the measurements. It shall be possible to turn the pump on and off by the user separately from the other instrument components. However, it shall not be possible to make a measurement when the pump is switched off.

*Note:* It is recommended that the gas handling system be flushed automatically with ambient air before the pump is switched off.

**6.1.7** The instrument shall be equipped with a device that indicates when the gas flow rate decreases to a level that would cause the detection to exceed either the response time or half the modulus of the maximum permissible error on initial verification. And, when that limit is reached, the device shall prevent measurements from being carried out.

The type of instrument is presumed to comply with this requirement if it passes test A.21 in Part 2 of this Recommendation.

**6.1.8** The gas handling system shall be airtight to such an extent that the influence of dilution with ambient air on the measurement results shall not be more than:

- for CO, CO<sub>2</sub> and HC: half the modulus of the maximum permissible error on initial verification;
- for O<sub>2</sub>: 0.1 % vol.

The instrument shall not be able to make a measurement if this value is exceeded.

A leakage test procedure with sufficient accuracy to detect this specific maximum leakage shall be provided in the manufacturer's operating instructions.

The type of instrument is presumed to comply with this requirement if it passes test A.22 in Part 2 of this Recommendation.

**6.1.9** The instrument may be equipped with an interface permitting coupling to any peripheral device(s) or other instrument(s).

An interface shall not allow the metrological functions of the instrument(s) or their measurement data to be influenced by the peripheral devices, by other interconnected instruments or by disturbances acting on the interface.

Functions that are performed or initiated via an interface shall meet the relevant requirements and conditions of clause 6.

If the instrument is connected to a data printer or an external data storage device, then the data transmission from the instrument to the printer shall be designed so that the results cannot be falsified.

It shall not be possible to print out a document or store the measuring data in an external device for legal purposes if the instrument checking facility(ies) detect(s) a significant fault or a malfunction.

Metrological requirements related to the durable recording of measurement results are defined in 5.4.

## 6.2 Adjustment facilities

**6.2.1** The instrument shall have an automatic facility that provides operations for zero-setting and adjustment.

**6.2.2** The internal adjustment shall neither influence the adjusted zero nor the linearity of the response of the instrument. These shall be coupled to any adjustment made with a reference gas. A method for coupling shall be provided such that each time a gas adjustment is conducted, the gas value and the internal adjustment value are adjusted and the indication equals the reference gas value.

**6.2.3** The instrument shall be provided with a means to observe negative indications near zero for some of the tests described in Part 2.

## 6.3 Security of operation

**6.3.1** If the detection of one or more of the disturbances listed in 5.7 is achieved by the use of automatic self-checking facilities, then it shall be possible to check the correct functioning of such facilities.

**6.3.2** Instruments with an HC-channel shall be equipped with a checking facility for detecting HC gas residues. This facility serves to ascertain that, before a measurement is made, the value indicated is less than 20 ppm vol n-hexane for an ambient air sample taken through the probe.

The type of instrument is presumed to comply with this requirement if it passes test A.23 in Part 2 of this Recommendation.

**6.3.3** The instrument shall not be able to make a measurement if the HC residue value exceeds 20 ppm vol n-hexane. If the instrument is provided with a measuring cycle, this requirement shall be fulfilled at the beginning of each measuring cycle; otherwise, the manufacturer shall indicate what constitutes the beginning of the measurement.

**6.3.4** Instruments with an O<sub>2</sub>-channel shall be equipped with a device for automatically recognizing any malfunctioning of the sensor due to aging or a break in the connecting line.

**6.3.5** The instrument shall be controlled by an automatic self-checking facility that shall operate in such a way that, before a measurement can be indicated or printed, all internal adjustments, reference gas adjustments, and all other checking facility parameters shall be confirmed for proper values or status (i.e. within limits). The checking facility for the instrument parameters shall, as a minimum requirement, be of the types given in Table 5.

**Table 5**

Instrument parameter	Type of checking facility <sup>a</sup>
a) Warm-up check	P
b) Low flow check	P
c) HC residue check	I
d) Internal reference adjustment check	I
e) Gas adjustment check	I
f) Leak check	I
<sup>a</sup> P = permanent automatic I = intermittent automatic	

**6.3.6** Instruments equipped with an automatic adjustment facility or a semi-automatic adjustment facility shall not be able to make a measurement until correct adjustments have been completed.

**6.3.7** Instruments equipped with a semi-automatic adjustment facility shall not be able to make a measurement when an adjustment is required.

**6.3.8** A means for warning of a required adjustment may be provided for both automatic and semi-automatic adjustment facilities.

**6.3.9** Effective sealing devices shall be provided on all parts of the instrument that are not materially protected in another way against operations liable to affect the accuracy or the integrity of the instrument.

This applies in particular to:

- adjustment means;
- software integrity;
- replaceable oxygen fuel cell.

**6.3.10** The software shall comply with the requirements in 6.3.10.1 and 6.3.10.2.

**6.3.10.1** The legally relevant software shall be secured against inadmissible modification, loading, or changes by swapping the memory device.

Parameters that fix legally relevant characteristics of the instrument shall be secured against unauthorized modification.

Protection comprises mechanical sealing and electronic or cryptographic means making an inadmissible intervention impossible or evident.

**6.3.10.2** Legally relevant software(s) of the instrument shall be clearly identified with the software version and a checksum (a CRC16 algorithm is an acceptable solution for this calculation). The software version may consist of more than one part but only one part shall be dedicated to the legal purpose.

The identification shall be inextricably linked to the software itself and shall be displayed or printed on command or displayed during operation.

**6.3.11** The metrological characteristics of an instrument shall not be influenced in any inadmissible way by the connection to it of another device, by any feature of the connected device itself or by any remote device that communicates with the measuring instrument.

**6.3.12** For instruments without a pressure compensating device, daily adjustment for the actual atmospheric pressure is required.

**6.3.13** A battery-operated instrument shall function correctly with new or fully charged batteries of the specified type and either continue to function correctly or not indicate any values whenever the voltage is below the manufacturer's specified value.

The type of instrument is presumed to comply with this requirement if it passes test A.9.3 in Part 2 of this Recommendation.

Specific voltage limits for road vehicle batteries are prescribed in 5.6.2, f).

## 7 Inscriptions and operating instructions

### 7.1 Inscriptions

**7.1.1** The instrument shall have a permanent, non-transferable, and easily readable label or labels giving the following information:

- a) Manufacturer's trademark/corporate name;
- b) Year of manufacture;
- c) Accuracy class designation in accordance with this Recommendation;
- d) Type approval mark and model number;
- e) Serial number of the instrument;
- f) Minimum and nominal flow rate;
- g) Details of the electrical power:
  - in case of mains power: the nominal mains voltage, frequency and power required;
  - in case of power by a road vehicle battery: the nominal battery voltage and power required;
  - in case of internal removable battery: the type and nominal voltage of the battery;
- h) Gas components and respective maximum measured value;
- i) Type description and model of the oxygen fuel cell;
- j) If the ambient temperature range or the range of atmospheric pressure differs from the standardized values (see 5.6.2, a) and c)), these special ranges shall be marked on the instrument;
- k) Identification of the legally relevant software (if applicable; see 7.1.3).

**7.1.2** The value of the propane/hexane equivalency factor (see 5.10) for each instrument shall be marked permanently and conspicuously to three significant figures on the front panel of the instrument, or shall be easily displayable on the indicating device.

In the case where more than one single propane/hexane equivalency factor is available, these factors shall be displayed with the associated volume fractions.

If a gas-sensitive element is replaced or repaired, the new conversion factor(s) shall be marked or displayed according to 7.1.2.

**7.1.3** For instruments with software-controlled metrological functions the identification of the legally relevant software shall be attached to a label in accordance with 7.1.1 or be displayable on the indicating device.

The instrument shall be provided with a facility to display the identification code mentioned in 6.3.10.

### 7.2 Operating instructions

**7.2.1** The manufacturer shall provide written operating instructions for each instrument in the language(s) of the country in which it will be used.

**7.2.2** The operating instructions shall include:

- a) The time intervals and the procedures for adjustment and maintenance that shall be followed to comply with the maximum permissible errors (see also 6.3.5, Table 5 and 6.3.12);
- b) A description of the leakage test procedure;
- c) An instruction for the user to conduct an HC residue check prior to each HC measurement, including a description of the HC residue check procedure;
- d) The maximum and minimum storage temperatures;



- e) If applicable, a specification of the voltage and frequency required of a portable generator, taking into account varying load conditions typical of those encountered at the location of use;
- f) A statement of the rated operating conditions listed in 5.6.2 and other relevant mechanical and electromagnetic environmental conditions;
- g) In case a lambda value is calculated, a description of the applied formula;
- h) An instruction for the replacement of the oxygen fuel cell;
- i) For instruments powered by an external power converter: specifications of this power converter;
- j) If applicable, details about compatibility with ancillary equipment;
- k) If the temperature range exceeds the range prescribed in 5.6.2, this wider range shall be included in the operating instructions;
- l) Any specific operating conditions, for example a limitation of the length of signal, data, or control lines, or special ranges for the ambient temperature and the atmospheric pressure;
- m) If applicable, the specifications of the battery (see 6.3.13);

## Part 2 - Metrological controls and tests

### 8 Metrological controls

#### 8.1 Type approval

##### 8.1.1 Documentation

When applying for type approval, the documentation supplied by the manufacturer for an instrument shall include:

- A description of its general principle of measurement;
- A list of its essential components with their characteristics;
- A description of its essential components with drawings and diagrams that are necessary for testing and maintenance;
- General information on the software required for a micro-processor equipped measuring instrument. In particular the requirement 6.3.10 shall be covered;
- In case a lambda calculation is included, a description of the applied formula with the values of the parameters and physical constants incorporated and evidence showing that the requirement of 5.11 is met;
- The operating instructions that shall be provided to the user.

Along with an application for type approval, the manufacturer shall provide any data or other information that may support the assertion that the design and construction of the instrument comply with the requirements of this Recommendation.

##### 8.1.2 General requirements

Type evaluation shall be carried out on at least one unit, which represents the definitive type. The evaluation shall consist of the tests specified in 8.1.3.

In order to accelerate the test procedure, the testing laboratory may carry out different tests simultaneously on different units. In this case, the testing laboratory shall ensure that all submitted instruments are of the same type.

All accuracy and influence tests and inspections shall be performed on the same unit, but disturbance tests may be carried out on not more than two additional instruments. See Table 6. In this case, the testing laboratory decides which test(s) to be carried out on which unit.

**Table 6**

Tests that shall be carried out on one and the same specimen					Tests that may be divided amongst no more than 2 additional instruments				
A.2	A.5	A.7	A.9	A.19	A.11	A.14	A.17	A.22	A.25
A.3	A.6	A.8	A.10	A.20	A.12	A.15	A.18	A.23	A.26
A.4					A.13	A.16	A.21	A.24	

##### 8.1.3 Inspection and tests

The inspection and testing of instruments is intended to verify compliance with the requirements of clauses 5, 6 and 7 of this Recommendation.

As a rule, tests should be carried out on the complete instrument. If the size or configuration of the instrument does not render it suitable to be tested as a unit or if only a particular component or device of the instrument is concerned, a test may be carried out on the component or device separately. Such tests may only be performed if a simulated measurement setup can be achieved that reflects the rated operating conditions of the component or device.

The contents of gas mixtures used during type approval shall conform to those specified in the normative Annex B.

*Note:* It is not intended that the instrument or its components should be dismantled for a test.

**8.1.3.1** An instrument shall be given a visual inspection to obtain a general appraisal of its design, construction, and conformity to the documentation submitted for type approval.

In particular, the following aspects shall be evaluated:

- a) Indication (5.1);
- b) Measuring range (5.2);
- c) Resolution (5.3);
- d) Durable storage or printing device (5.4);
- e) Construction (6.1);
- f) Adjustment facilities (6.2);
- g) Security of operation (6.3);
- h) Inscriptions (7.1);
- i) Operating instructions (7.2);
- j) Sealing devices (6.3.9); and
- k) Consequence of malfunctioning of O<sub>2</sub> sensor (6.3.4).

**8.1.3.2** The EUT shall be submitted to the performance tests specified in clause 9 to determine its correct functioning.

## **8.2 Initial verification**

### **8.2.1 General requirements**

A new instrument shall undergo initial verification only after type approval. The verification shall be carried out using suitable testing means and certified reference gases.

### **8.2.2 Inspection**

Before starting the tests, the following inspections shall be performed:

- a) A visual inspection to determine conformance with the approved type;
- b) A check of the power supply voltage and frequency at the location of use to determine compliance with the specifications on the measuring instrument's label.

### **8.2.3 Tests**

The tests to determine the errors of the instrument shall be carried out under rated operating conditions.

- a) Before starting the tests, adjust the instrument according to the routine adjustment procedure described in the manufacturer's operating instructions.
- b) After the instrument has warmed up, determine the error curve according to test A.2 in Annex A. The oxygen channel shall be tested for zero reading and span reading using a reference gas without oxygen (only CO and/or CO<sub>2</sub> and/or HC in N<sub>2</sub>) and a reference gas containing 20.9 % vol O<sub>2</sub>.

The reference gases shall be supplied at the probe at ambient pressure (to within 8 hPa).

The errors observed shall be within the limits of the maximum permissible errors of 5.5.2 on initial verification for each measurement.

- c) Check the air-tightness of the system by performing a leak check as described in the manufacturer's operating instructions.
- d) Check for HC residues with the procedure described in the manufacturer's operating instructions.
- e) Check for the activation of the low gas flow device, and also for the low flow lockout, by restricting the gas flow supplied to the probe while sampling ambient air.
- f) Check the response time of the CO channel and the O<sub>2</sub> channel.

#### **8.2.4 Gases to be used for initial verification**

Initial verification may be performed with pure N<sub>2</sub> and the gas mixtures E, F, G, and/or H as specified in Table B.1 of Annex B.

In addition, for Class 00 and Class 0 instruments, a test with gas mixture L shall be performed.

### **8.3 Subsequent verification**

#### **8.3.1 General requirements**

The subsequent verification shall be carried out using suitable testing means and certified reference gases.

The interval for subsequent verification is subject to national or regional legislation. This Recommendation, however, suggests an interval not exceeding 1 year.

#### **8.3.2 Inspection**

Before starting the tests, a visual inspection shall be performed to determine the validity of the previous verification and the presence of all required stamps, seals and documents.

#### **8.3.3 Tests for subsequent verification**

All tests according to 8.2.3 shall be performed.

#### **8.3.4 Gases to be used for subsequent verification**

Subsequent verification may be performed with pure N<sub>2</sub> and the gas mixtures E, F, G, and/or H as specified in Table B.1 of Annex B.

In addition, for Class 00 and Class 0 instruments, a test with gas mixture L shall be performed.

## **9 Performance tests for type approval**

Prior to the type approval tests and when specified in the manufacturer's operating instructions provided under 8.1.1 f), the instrument shall be adjusted with reference gases according to these instructions. The reference gases shall be supplied to the probe at ambient pressure (to within 8 hPa).

### **9.1 Check of the error curve**

This test shall be carried out under reference conditions according to test A.2 in Annex A. During this test, the errors shall not exceed the maximum permissible intrinsic error of 5.5.1 for any measurement.

### **9.2 Stability with time or drift**

This test shall be carried out according to test A.3 in Annex A, under reference conditions. During this test, the requirements of 5.12 shall be met.

### **9.3 Repeatability**

This test shall be carried out according to test A.4 in Annex A, under reference conditions. During this test, the requirements of 5.13 shall be met.

### **9.4 Effect of influence quantities**

As a rule, only one influence quantity should be varied during a test while all the others are kept at their reference values.

#### 9.4.1 Environmental conditions and electrical supply

The following tests a) to e) cover the rated operating conditions specified in 5.6.2.

During the tests a) to d), the indications of the instrument shall remain within the maximum permissible error on initial verification.

During the test e), the variation of indication shall not be larger than half the modulus of the maximum permissible error on initial verification.

- a) Dry heat: ..... see test A.5;
- b) Cold: ..... see test A.6;
- c) Damp heat, steady state: ..... see test A.7;
- d) Atmospheric pressure: ..... see test A.8;
- e) Voltage and frequency variation: ..... see test A.9.

#### 9.4.2 Influence of other gas components on the measurand (cross sensitivity)

This test shall be carried out under reference conditions except for the presence of influencing gas components (5.6.1 f). During this test (see A.10), the requirements of 5.6.3 shall be met where the absolute value of the variation of the indication found shall not exceed half the modulus of the maximum permissible error on initial verification.

#### 9.5 Disturbances

Significant faults shall either not occur or shall be detected by means of checking facilities, during the following tests, carried out to verify the requirements of 5.7 for the instruments under rated operating conditions (as specified in 5.6.2):

- a) Mechanical shock and vibrations: ..... see test A.11;
- b) AC mains voltage dips and short interruptions: ..... see test A.12;
- c) Bursts (transients) on AC mains, signal, data, and control lines: ... see test A.13;
- d) Transient conduction in case of a road vehicle battery: ..... see test A.14;
- e) Electrostatic discharges: ..... see test A.15;
- f) Surges on signal, data, control, and power lines: ..... see test A.16;
- g) Radio frequency electromagnetic fields: ..... see test A.17;
- h) Mains frequency magnetic fields: ..... see test A.18.

#### 9.6 Tests for conformity to other technical and metrological requirements

The instruments shall be tested for conformity to the following requirements:

- a) Warm-up time according to 5.9: ..... see test A.19;
- b) Response time according to 5.8: ..... see test A.20;
- c) Low flow according to 6.1.7: ..... see test A.21;
- d) Leakage according to 6.1.8: ..... see test A.22;
- e) HC residue according to 6.3.2: ..... see test A.23;
- f) Filter unit according to 6.1.3: ..... see test A.24;
- g) Water separator according to 6.1.4: ..... see test A.25;
- h) Propane/hexane equivalency factor according to 5.10: ..... see test A.26.

**9.7 Source of power for type evaluation**

If applicable, the appropriate source of power for field use of instruments shall be specified in the manufacturer's operating instructions. If a source of power is specified in addition to the mains, for example a battery or portable generator, then the instrument shall undergo relevant type tests with each source of power with which it is intended to operate.

Each test specified in Annex A (normative/mandatory) shall be started and completed without changing or recharging the power source.

---

## **Annex A**

### **Description of performance tests for type approval**

#### **(Normative/mandatory)**

#### **A.1 General**

The HC volume fractions specified for these tests are expressed in terms of n-hexane. However, propane may be used as the HC component of the reference gas as required for each performance test except test A.26 (see 1 and 5.10).

It is necessary to consult the referent publications before conducting the tests.

If the instrument is equipped with a lambda indication, the displayed value of lambda is recorded for each test and compared to the value calculated with the formula specified in Annex D. In accordance with 5.11, the difference shall not exceed 0.3 %.

#### **A.2 Error curve**

The errors of the instrument shall be determined separately for each measurand and for at least three values within their measuring range using the recommended volume fractions according to the mixtures E, F, and G and/or H in Table B.1 of Annex B.

In addition, for Class 00 and Class 0 instruments, a test with gas mixture L shall be performed.

The measurements shall be performed successively.

#### **A.3 Stability with time or drift**

This test shall be conducted for a period of 4 h following the warm-up time. Measurements shall be performed at least every half-hour using the recommended volume fractions according to the mixture A in Table B.1 of Annex B.

#### **A.4 Repeatability**

The requirement specified in 5.13 shall be tested with the recommended volume fractions according to the mixture A in Table B.1 of Annex B. Between each measurement, the instrument shall return under "free air".

#### **A.5 Dry heat**

**A.5.1** This test consists of exposure of the instrument to a temperature of 40 °C (or 55 °C if specified by the manufacturer in accordance with 5.6.2) under "free air" conditions for 2 h (the time duration specified begins after the instrument has reached temperature stability). During the test, the rate of change in temperature shall not exceed 1 °C/min during heating up and cooling down, and the relative humidity in the testing atmosphere shall not exceed 50 %.

See IEC 60068-2-2, IEC 60068-3-1.

**A.5.2** The reference gas shall be supplied to the probe at ambient pressure (to within 8 hPa). During the test, one measurement shall be performed every half-hour using the two mixtures composed of the recommended volume fractions according to the mixtures A and C in Table B.1 of Annex B.

## A.6 Cold

**A.6.1** This test consists of exposure of the instrument to a temperature of 5 °C under “free air” conditions for 2 h (the time duration specified begins after the instrument has reached temperature stability). During the heating up or cooling down of the instrument, the rate of change in temperature shall not exceed 1 °C/min.

See IEC 60068-2-1, IEC 60068-3-1.

**A.6.2** The reference gas shall be supplied to the probe at ambient pressure (to within 8 hPa). During the test, one measurement shall be performed every half-hour using two mixtures composed of the recommended volume fractions according to the mixtures A and C in Table B.1 of Annex B.

## A.7 Damp heat, steady state

**A.7.1** This test consists of exposure of the instrument to a constant temperature of 30 °C and a constant relative humidity of 85 % for two days. The exposure shall be such that water does not condense on the instrument. The temperature is deemed to be steady when the difference between the extreme temperatures does not exceed 5 °C, and the rate of change does not exceed 5 °C/h.

See IEC 60068-2-78.

**A.7.2** The reference gas shall be supplied to the probe at ambient pressure (to within 8 hPa). During the test, one measurement shall be performed every day using two mixtures composed of the recommended volume fractions according to the mixtures A and C in Table B.1 of Annex B.

## A.8 Atmospheric pressure

**A.8.1** The test consists of measurements under the extreme pressures of the rated operating conditions (860 hPa to 1060 hPa) or extreme pressures outside these limits when specified by the manufacturer.

The extreme values shall be reached gradually from stable ambient pressure conditions and shall then be kept stable during 30 min before starting the measurements as specified in A.8.2.

**A.8.2** Reference gases shall be supplied at the probe at ambient test pressure (to within 8 hPa).

The measurements shall be performed using two mixtures composed of the recommended volume fractions according to the mixtures A and C in Table B.1 of Annex B at the following pressures:

- ambient pressure;
- extreme high pressure;
- extreme low pressure;
- ambient pressure.

For each measurement, the errors observed shall be within the limits of the maximum permissible errors specified in 5.5.2, Table 4 on initial verification.

*Note:* If an automatic or semi-automatic adjustment is part of the pressure compensation process, care must be taken to ensure that the measurements at both extreme pressure values are performed after such adjustment has been carried out.

See: OIML D 11:2004, 10.4.1, severity level 2.



## A.9 Voltage and frequency variation

In case the instrument can be used with more than one source of power, all relevant tests A.9.1 to A.9.3 shall be carried out independently.

### A.9.1 AC mains voltage and frequency

Instruments intended to be powered by AC mains power are subjected to an AC mains voltage variation test and an AC mains frequency variation test, consisting of exposure of the instrument to extreme values of the mains voltage  $U$  and frequency  $f$  for a period long enough to perform the required measurement. The conditions given in Table A.1 shall be applied.

**Table A.1**

Parameter	Unit	Relative tolerance
Mains voltage $U$	Volt	Nominal voltage + 10 % Nominal voltage – 15 %
Mains frequency	Hertz	Nominal frequency $\pm$ 2 %

See IEC/TR 61000-2-1, IEC 61000-4-1.

### A.9.2 Voltage of a road vehicle battery

The test consists of exposure of the instrument to the high voltage and the low voltage as specified in Table A.2 for a period long enough to perform the required measurement. In case the test is not performed with a normal road vehicle battery, but by means of a laboratory power supply, the internal resistance of the battery shall be simulated. This is particularly important for the low voltage test.

**Table A.2**

Nominal voltage	12 V	24 V
Low voltage	9 V	16 V
High voltage	16 V	32 V

### A.9.3 Voltage of an internal battery

The test consists of exposure of the instrument to the voltage of a new or fully charged battery and the low voltage as specified by the manufacturer for a period long enough to perform the required measurement. In case the test is not performed with a normal battery as specified, but by means of a laboratory power supply, the internal resistance of the battery shall be simulated. This is particularly important for the low voltage test.

**A.9.4** While the instrument is exposed separately to each appropriate type of variations indicated in A.9.1, A.9.2, or A.9.3, the measurements shall be performed using the recommended volume fractions according to the mixture A in Table B.1 of Annex B.

## A.10 Influence of other gas components on the measurand (cross sensitivity)

**A.10.1** The cross sensitivity shall be determined by the following two tests:

**A.10.1.1** Test with one component:

- a) Supply the instrument with  $N_2$  alone.
- b) Supply the instrument successively with each influencing gas alone in  $N_2$  (binary mixtures) at its maximum value as specified in 5.6.3.
- c) Compare the “zero” responses of the instrument determined in a) and b) for each measurand. The difference of indications shall meet the requirements specified in 5.6.3 for “zero”.

**A.10.1.2** Test with all measurands in N<sub>2</sub>:

- a) Supply the instrument with a measurand in N<sub>2</sub> alone. Repeat the operation for the other measurands.
- b) Supply the instrument with all measurands together in N<sub>2</sub>.
- c) For each measurand, the difference between the errors of the instrument determined in a) and the error determined in b) shall meet the requirements specified in 5.6.3.

**A.10.2** For the test in A.10.1.2 and for instruments that detect with infra-red absorption and for O<sub>2</sub> channel, the volume fractions according to gas D in Table B.1 of Annex B, fully saturated with moisture (humidity > 95 %), are recommended.

Referring to 5.6.3, if the presence of O<sub>2</sub> and H<sub>2</sub> is necessary, two different gas mixtures shall be used to avoid explosive risk. The recommended volume fractions for the measurand in N<sub>2</sub> are the volume fractions according to the mixtures J and K in Table B.1 of Annex B.

**A.11 Mechanical shock and vibrations**

**A.11.1** For mechanical shock testing, the tested instrument shall be placed in its normal position of use on a rigid surface. It shall be tilted on one bottom edge and then allowed to fall freely onto the test surface.

The following conditions shall be applied:

- height of fall: 25 mm;
- number of falls: 1 on each bottom edge.

See IEC 60068-2-31.

**A.11.2** For vibration testing (only for hand-held instruments as defined in 3.35), the instrument shall be mounted in its normal position. It shall be exposed to random vibrations with the following conditions:

- total frequency range: 10 Hz to 150 Hz;
- total RMS level: 1.6 m·s<sup>-2</sup> ;
- ASD level 10 Hz to 20 Hz: 0.05 m<sup>2</sup>·s<sup>-3</sup> ;
- ASD level 20 Hz to 150 Hz: - 3 dB/octave;
- number of axes: 3;
- duration per axis: 2 min.

See IEC 60068-2-64.

**A.11.3** Before and after each test, measurements shall be performed using the recommended volume fractions according to mixture A in Table B.1 of Annex B.

**A.12 AC mains voltage dips and short interruptions**

**A.12.1** A test generator shall be used suitable to reduce, for a defined period of time, the amplitude of the AC mains voltage. It shall be adjusted before being connected to the instrument.

For the voltage dips, all three tests according to Table A.3 shall be applied.

The voltage reductions shall be repeated 10 times with an interval of at least 10 seconds between the tests.

**Table A.3**

Voltage dips	Test a	Down to		0 %
		Duration		0.5 cycles
	Test b	Down to		0 %
		Duration		1 cycle
	Test c	Down to		70 %
		Duration	50 Hz	25 cycles
60 Hz			30 cycles	
Short interruptions	Down to		0 %	
	Duration	50 Hz	250 cycles	
		60 Hz	300 cycles	

See IEC 61000-4-11.

**A.12.2** During the test, measurements shall be performed using the recommended volume fractions according to mixture A in Table B.1 of Annex B.

### **A.13 Bursts (transients)**

**A.13.1** The test consists of exposure to bursts of voltage spikes on power ports, protective ground/earth, and Input/Output signal, data and control ports.

The injection network on the mains shall contain blocking filters to prevent the burst energy from being dissipated in the mains.

For the coupling of the bursts into the I/O and communication lines and ports for external battery power, a capacitive coupling clamp as defined in the Standard shall be used.

The test shall be performed under the conditions given in Table A.4.

**Table A.4**

	<b>AC mains power ports and protective ground/earth</b>	<b>Input/Output signal, data and control ports</b>
Test voltage	1 kV	0.5 kV
Repetition rate	5 kHz	
Polarity of the bursts	Both positive and negative	
Duration of the test	≥ 1 minute	

See IEC 61000-4-4.

**A.13.2** During the test, measurements shall be performed using the recommended volume fractions according to mixture A in Table B.1 of Annex B.

### **A.14 Electrical transient conduction in case of road vehicle battery**

**A.14.1** Electrical transient conduction along supply lines

The instrument is subjected to the disturbances listed in Table A.5

For more details of the test and the shape of the pulses, the referent ISO Standard shall be consulted.

**Table A.5**

Pulse <sup>(1)</sup>	$U_n$ <sup>(2)</sup>	12 V	24 V
2a	$U_s$	+ 50 V	+ 50 V
2b <sup>(3)</sup>	$U_s$	+ 10 V	+ 20 V
3a	$U_s$	- 150 V	- 200 V
3b	$U_s$	+ 100 V	+ 200 V
4	$U_s$	- 7 V	- 16 V

<sup>(1)</sup> Pulses according to ISO 7637-2, test level IV  
<sup>(2)</sup>  $U_n$  = Nominal battery voltage,  $U_s$  = Pulse voltage  
<sup>(3)</sup> Test pulse 2b is only necessary if the measuring instrument may be connected to the battery via the main (ignition) switch of the car, i.e. if the manufacturer of the measuring instrument has **not** specified that the instrument is to be connected directly (or by its own main switch) to the battery.

**A.14.2** Electrical transient conduction via lines other than supply lines

The instrument is subjected to the disturbances listed in Table A.6

For more details of the test and the shape of the pulses, the referent ISO Standard shall be consulted.

**Table A.6**

Pulse <sup>(1)</sup>	$U_n$ <sup>(2)</sup>	12 V	24 V
a	$U_s$	- 60 V	- 80 V
b	$U_s$	+ 40 V	+ 80 V

<sup>(1)</sup> Pulses according to ISO 7637-3, test level IV  
<sup>(2)</sup>  $U_n$  = Nominal battery voltage,  $U_s$  = Pulse voltage

**A.14.3** During the test, measurements shall be performed using the recommended volume fractions according to mixture A in Table B.1 of Annex B.

**A.15 Electrostatic discharges**

**A.15.1.1** For instruments not equipped with a ground terminal, the instrument shall be fully discharged between discharges.

Contact discharge is the preferred test method. Air discharges shall be used where contact discharge cannot be applied.

**A.15.1.2** Direct application

In the contact discharge mode to be carried out on conductive surfaces, the electrode shall be in contact with the EUT.

In the air discharge mode on insulated surfaces, the electrode is approached to the EUT and the discharge occurs by spark.

**A.15.1.3** Indirect application

The discharges are applied in the contact mode to coupling planes mounted in the vicinity of the EUT.

**A.15.1.4** The test shall be performed under the following conditions:

- Contact discharge: 6 kV
- Air discharge: 8 kV
- Number of discharges:  $\geq 10$
- Time interval between discharges:  $\geq 10$  s

See IEC 61000-4-2.

**A.15.2** During the test, measurements shall be performed using the recommended volume fractions according to mixture A in Table B.1 of Annex B.

## A.16 Surges on signal, data, control and power lines

**A.16.1** The tests consist of exposure to surges for which the rise time, pulse width, peak values of the output voltage/current on high/low impedance load and minimum time interval between two successive pulses are defined in the referent Standard. The test levels shall be as specified in Table A.7.

At least 3 positive and 3 negative surges shall be applied.

On AC mains supply lines at least three positive and three negative surges shall be applied synchronously with AC supply voltage in angles  $0^\circ$ ,  $90^\circ$ ,  $180^\circ$  and  $270^\circ$ .

For these tests, supply lines for power by an external battery shall be considered as “signal, data, and control lines”.

The tests on signal, data and control lines may be omitted if, according to the manufacturer's specifications, the length of these lines does not exceed 30 m (see item l) in 7.2.2). In this case, the reason for omitting the test shall be noted in the test report.

**Table A.7**

Signal, data, and control lines	Symmetrical and shielded	line to line	N/A
		line to ground	2 kV
	Unsymmetrical	line to line	1 kV
		line to ground	2 kV
Mains power lines	line to line	1 kV	
	line to ground	2 kV	

See IEC 61000-4-5.

**A.16.2** During the test, measurements shall be performed using the recommended volume fractions according to mixture A in Table B.1 of Annex B.

## A.17 Radio frequency immunity

IEC 61000-4-3 only specifies test levels above 80 MHz. For frequencies below 80 MHz, the test methods for conducted radio frequency disturbances are recommended (test A.17.2).

However, for EUT having no mains or other input port available, the lower limit of the radiation test should be 26 MHz taking into account that the test specified in A.17.2 cannot be applied (refer to Annex H of IEC 61000-4-3). In all other cases both A.17.1 and A.17.2 shall apply.

### A.17.1 Radiated, radio frequency, electromagnetic fields

**A.17.1.1** Instruments shall be exposed to an electromagnetic field strength as follows:

- frequency range: 80 MHz to 2 GHz;
- field strength: 10 V/m;
- modulation: 80 % AM, 1 kHz sine wave.

**A.17.1.2** The frequency ranges to be considered are swept with the modulated signal, pausing to adjust the RF signal level or to switch oscillators and antennas as necessary. Where the frequency range is swept incrementally, the step size shall not exceed 1 % of the preceding frequency value.

The dwell time of the amplitude modulated carrier at each frequency shall not be less than the time necessary for the EUT to be exercised and to respond, but shall in no case be less than 0.5 s.

The sensitive frequencies (for example clock frequencies) shall be analyzed separately.

See IEC 61000-4-3.

*Note:* Usually, these sensitive frequencies can be expected to be the frequencies emitted by the EUT (see 12.1.1 of OIML D 11:2004).

## **A.17.2 Conducted radio frequency fields**

If the EUT is composed of several elements, the tests shall be performed at each extremity of the cable if both of the elements are part of the EUT.

**A.17.2.1** Instruments shall be exposed, as follows, to a conducted radio frequency field:

- frequency range: 0.15 MHz to 80 MHz;
- RF amplitude (50  $\Omega$ ): 10 V (e.m.f.);
- modulation: 80 % AM, 1 kHz sine wave.

**A.17.2.2** Radio frequency EM current, simulating the influence of EM fields, shall be coupled or injected into the power ports and I/O ports of the EUT using coupling/decoupling devices as defined in the referent Standard.

See IEC 61000-4-6.

**A.17.3** During the test, measurements shall be performed using the recommended volume fractions according to mixture A in Table B.1 of Annex B.

## **A.18 Mains frequency magnetic fields**

The instrument tested shall be exposed in all directions to a magnetic field of 30 A/m at mains frequency.

See IEC 61000-4-8.

During the test, measurements shall be performed using the recommended volume fractions according to mixture A in Table B.1 of Annex B.

## **A.19 Warm-up time**

**A.19.1** At reference conditions and at 5 °C, the warm-up time test to verify compliance with 5.9 shall consist of the following steps:

- a) Stabilize the instrument at each temperature;
- b) Let the instrument warm up;
- c) Immediately after either the manufacturer's prescribed warm-up period has elapsed or an automatic warm-up lockout has been deactivated, perform a volume fraction measurement (with any necessary internal adjustment being performed prior to this measurement) using the recommended volume fractions according to mixture A in Table B.1 of Annex B;
- d) At time intervals of 2 min, 5 min and 15 min after warm-up, perform a measurement with the same reference gas as in step c).

**A.19.2** The difference between any of the four measured values in c) and d) in A.19.1 shall not exceed the modulus of the maximum permissible error on initial verification as defined in 5.5.2.

*Note:* At reference conditions, the warm-up time test may be included with the drift test (A.3).

## **A.20 Response time**

**A.20.1** A measurement shall be taken to determine the time required for an instrument to respond to a reference gas after sampling ambient air supplied at the probe. A means shall be employed for instantly changing from sampling ambient air to sampling reference gas through the probe. The gases shall be supplied at the probe at ambient pressure (to within 8 hPa). The response time shall not exceed the appropriate values specified in 5.8.

**A.20.2** The recommended volume fractions according to mixture B in Table B.1 of Annex B shall be used.

## **A.21 Low flow**

**A.21.1** A measurement shall be performed with a reference gas that is initially supplied to the gas handling system at a gas flow rate greater than the minimum required by the tested instrument. During the measurement, the gas flow rate shall be reduced until the low flow indicator responds according to the requirements of 6.1.7.

**A.21.2** The recommended volume fractions according to mixture B in Table B.1 of Annex B shall be used.

## **A.22 Leakage**

**A.22.1** When a gas mixture is used, the adjustment of the leakage and the test shall be performed successively for each component.

**A.22.2** An adjustable leak shall be artificially introduced into the gas handling system near the pump where a leak of an appropriate orifice size will have the greatest effect on the measurement. With this artificial leak closed, a reference gas shall be supplied at the probe at ambient pressure (to within 8 hPa).

**A.22.3** While sampling the reference gas, record the indication and then adjust the leakage rate so that the indication of the reference gas differs from the value indicated previously (without the leak) by an amount equal to the requirement of 6.1.8. Without disturbing the artificial leak, remove the reference gas supplied at the probe, and conduct the leakage test procedure as described in the manufacturer's operating instructions.

**A.22.4** The recommended volume fractions according to mixture B in Table B.1 of Annex B shall be used.

*Note:* Since the leakage test is performed by introducing air into the system, the reference gas supplied at the probe should have a volume content of O<sub>2</sub> close to 0 %.

## **A.23 HC residue**

**A.23.1** The exhaust of a specially adjusted test engine shall be sampled for at least 5 min by an instrument in thermal equilibrium at 5 °C. The exhaust gas shall contain at least 5 % CO and 800 ppm HC.

Immediately after the sampling, conduct an HC residue check as described in the manufacturer's operating instructions. Repeat this operation as many times as necessary to obtain an HC residue that complies with the requirements of 6.3.2. Then reference gases shall be supplied to the probe to check compliance with the maximum permissible error on initial verification.

**A.23.2** For this test, the measurements shall be performed using the recommended volume fractions according to mixture I in Table B.1 of Annex B, which shall be supplied at the probe at ambient pressure (to within 8 hPa).

## **A.24 Filter unit**

**A.24.1** At reference conditions, the instrument shall be exposed to exhaust gases from a specially adjusted test engine for a period of at least 30 min according to A.23.1.

Immediately after the sampling, conduct an HC residue check as described in the manufacturer's operating instructions. Repeat this operation as many times as necessary to obtain an HC residue that complies with the requirements of 6.1.3.2. The instrument shall be checked immediately with a reference gas that shall be supplied to the gas handling system at ambient pressure (to within 8 hPa). The instrument shall comply with the requirements for the maximum permissible error on initial verification and for the response time.

**A.24.2** The test shall be carried out using the recommended volume fractions according to mixture D in Table B.1 of Annex B.

## **A.25 Water separator**

**A.25.1** The water separator shall be subjected to the following two tests.

a) High temperature test:

- stabilize the instrument at 40 °C (or 55 °C if specified by the manufacturer in accordance with 5.6.2); and
- expose the instrument to water saturated N<sub>2</sub> at 40 °C (or 55 °C if specified by the manufacturer in accordance with 5.6.2), or water saturated ambient air at 40 °C (or 55 °C if specified by the manufacturer in accordance with 5.6.2), supplied to the gas handling system for 30 min.

b) Low temperature test:

- stabilize the instrument at a low ambient temperature within the rated operating conditions; and
- expose the instrument to exhaust gases from any (except two stroke engine) car attached to the probe for 30 min.

**A.25.2** After each test, the instrument shall be checked immediately with the volume fractions of gases according to the mixture D in Annex C. It shall comply with the requirements of the maximum permissible error on initial verification and with the response time requirements of 5.8 before and after the test.

## **A.26 Propane/hexane equivalency factor**

**A.26.1** Test procedure

- a) Make a measurement for each of the following recommended volume fractions of propane reference gas: 200 ppm vol and 2 000 ppm vol;
- b) Calculate the absolute error of the instrument for each of the two volume fractions of propane reference gas used in a). To this end, the true value is determined with the formula:

$$I_{\text{true}} = C \times \text{PEF}$$

Where:

*C* is the true value of the volume fraction of propane, and

PEF is the value of the propane/hexane equivalency factor given by the manufacturer;



- c) Make a measurement for each of the following recommended fractions of hexane reference gas: 100 ppm vol and 1 000 ppm vol;
- d) Calculate the absolute error of the instrument for each of the two volume fractions of hexane used in c);
- e) For each of the two volume fractions, calculate the difference between the error obtained with propane and that obtained with hexane.

**A.26.2** The difference between the errors shall not exceed (according to the case; see 5.10) the applicable maximum permissible intrinsic error or half of the applicable maximum permissible intrinsic error as defined in 5.5.1.

*Note:* It is assumed that the errors of the instruments are constant both near 100 ppm vol and near 1 000 ppm vol.

---

## **Annex B**

### **Designation of reference gases and their composition**

(Normative/mandatory)

#### **B.1 General requirements**

**B.1.1** The reference gases shall be supplied either in gas cylinders or by dynamic blending.

Gas mixtures in gas cylinders shall meet the requirements of ISO 6142.

Blended gases shall meet the requirements of ISO 6145 as well as those of B.1.2 and B.2.

**B.1.2** The composition of reference gases shall be certified as complying with the requirements of B.2 and as being traceable to national, regional or international standards.

**B.1.3** The material of gas cylinders shall be inert to the gases contained therein.

#### **B.2 Specifications and uncertainties of composition of the gas mixtures**

**B.2.1** The unit for the quantity of gases contained or delivered shall be either in molar or volume fractions (see 5.1).

**B.2.2** The blend tolerances of the reference gas mixtures shall not exceed 15 % of the volume fraction of each component.

**B.2.3** For gas mixtures, the expanded uncertainty in the composition shall be 1 % or less of the volume fraction of each measurand except for HC of 1 000 ppm and below, where the expanded uncertainty shall be 2 % or less in case of Class I or 0 and 1 % or less in case of Class 00. The composition of each component not subject to measurement shall have an expanded uncertainty of 5 % or less.

The specified expanded uncertainty values are values relative to the standards referred to in B.1.2, based on a coverage factor  $k = 2$ .

#### **B.3 Preparation of gases in special cases**

**B.3.1** Propane shall be used for reference gas mixtures requiring HC. Therefore the propane/hexane equivalency factor shall be taken into account.

**B.3.2** Volume fractions of O<sub>2</sub>, H<sub>2</sub>, NO, and water vapor shall be blended with the other gases as required during the tests specified in Annex A. The volume fraction of water vapor required shall not be supplied in high pressure gas cylinders because of instability and corrosion effects.

**B.3.3** Ambient air shall be drawn through a charcoal filter or equivalent system when it is used to set zero for instruments measuring HC.

## B.4 Composition of the gas mixtures used for the tests

The gas mixtures to be used for the performance tests in Annex A are listed in Table B.1:

**Table B.1 Composition of the gas mixtures used for the tests in Annex A** <sup>(1), (2)</sup>

Component	Unit	Gas mixture											
		A	B	C	D	E	F	G	H	I	J	K	L <sup>(5)</sup>
CO	% vol	0.5	0.5	3.5	3.5	0.5	1	3.5	5	3.5	3.5	3.5	0.25
CO <sub>2</sub>	% vol	14	14	14	14	6	10	14	14	-	14	14	3
HC <sup>(3)</sup>	ppm vol	100	100	1000	1000	100	300	1000	1000	1000	1000	1000	40
O <sub>2</sub>	% vol	0.5	0	0.5	0	0.5	10	20.9	20.9	-	10	-	0
H <sub>2</sub>	% vol	-	-	-	-	-	-	-	-	-	-	5	-
Used in test	A.2					X	X	X	X				X
	A.3	X											
	A.4	X											
	A.5	X		X									
	A.6	X		X									
	A.7	X		X									
	A.8	X		X									
	A.9	X											
	A.10				X						X	X	
	A.11	X											
	A.12	X											
	A.13	X											
	A.14	X											
	A.15	X											
	A.16	X											
	A.17	X											
	A.18	X											
	A.19	X											
	A.20			X									
	A.21			X									
	A.22			X									
	A.23									X			
	A.24					X							
	A.25					X							
	<i>Note 1</i>	As stated in 8.1.3, the base gas is N <sub>2</sub> for all gas mixtures.											
<i>Note 2</i>	The values in this Table are the nominal values of the gas components. For the maximum difference between this nominal value and the actual value, refer to B.2.2. For the maximum uncertainty of the actual value, refer to B.2.3.												
<i>Note 3</i>	The HC volume fractions specified in this Table are expressed in terms of n-hexane; however, propane may be used as the HC component of the reference gas.												
<i>Note 4</i>	For the binary gases to be used, refer to the text of the appropriate tests.												
<i>Note 5</i>	For instruments of Class 0 and Class 00 only.												

Other gases necessary for the evaluation and tests are summarized in Table B.2:

**Table B.2 Other gases**

<b>Used in test</b>	<b>Description of the gas mixture</b>
A. 23.1 + A.24.1	Exhaust gas of specially tuned engine containing at least 5 % CO and 800 ppm HC
8.2.3, b)	Reference gas containing 0 % vol O <sub>2</sub>
8.2.3, b)	Reference gas containing 20.9 % vol O <sub>2</sub>
A.10.1.1	Pure N <sub>2</sub>
A.10.1.1	Binary mixture 16 % vol CO <sub>2</sub> in N <sub>2</sub>
A.10.1.1	Binary mixture 6 % vol CO in N <sub>2</sub>
A.10.1.1	Binary mixture 10 % vol O <sub>2</sub> in N <sub>2</sub>
A.10.1.1	Binary mixture 5 % vol H <sub>2</sub> in N <sub>2</sub>
A.10.1.1	Binary mixture 0.3 % vol NO in N <sub>2</sub>
A.10.1.1	Binary mixture 2 000 ppm vol HC (as n-hexane) in N <sub>2</sub>
A.10.1.1 + A.10.2	Water vapor up to saturation in N <sub>2</sub> .
A.10.1.2	6 % vol CO + 16 % vol CO <sub>2</sub> + 10 % vol O <sub>2</sub> + 2 000 ppm vol HC (as n-hexane) in N <sub>2</sub>
A.25	Water saturated N <sub>2</sub> at 40 °C, or water saturated ambient air at 40 °C
A.25	Exhaust gases from any (except two stroke engine) car
A.26	200 ppm vol propane in N <sub>2</sub>
A.26	2 000 ppm vol propane in N <sub>2</sub>
A.26	100 ppm vol hexane
A.26	1 000 ppm vol hexane

**Annex C**  
**Procedure for routine testing**  
(Informative)

A routine test of the instrument should consist of at least the following:

- a) Perform an internal adjustment check within 1 hour after performing each vehicle test;
- b) Check for HC residues before testing each vehicle;
- c) Check the instrument's gas internal adjustment with a reference gas at intervals specified by the responsible legal authority or recommended in the manufacturer's operating instruction manual;
- d) Perform a leak check at least once a day. Repair any leaks and conduct a successful leak check before testing any vehicle;
- e) Conduct a leak check after each disassembly of the gas handling system (e.g. a probe or filter element replacement). Repair any subsequent leaks and conduct a successful leak check before testing any vehicle.

## Annex D

### Lambda calculation

(Normative/mandatory<sup>1</sup>)

#### D.1 Introduction

The value of lambda depends on the composition of the fuel, the air that is used for the combustion and on the combustion products as found in the exhaust gases.

A basic formula, taking into account:

- components of the fuel: carbon, hydrogen, oxygen and water content;
- water content of the air; and
- components of the exhaust gases: carbon dioxide, carbon monoxide, hydrocarbons and nitrogen oxide

has been developed by J. Brettschneider<sup>2</sup>.

A simplified formula, derived from the basic formula and based on the assumption that the water content of fuel and air and the NO<sub>x</sub> content in the exhaust gases are negligible, allows the computation of lambda when certain components of the exhaust are measured.

#### D.2 Simplified lambda formula

For lambda calculation, based upon measurements of CO, CO<sub>2</sub>, HC and O<sub>2</sub>, the following formula is standardized:

$$\frac{[CO_2] + \frac{[CO]}{2} + [O_2] + \left\{ \left( \frac{H_{cv}}{4} \times \frac{3.5}{3.5 + \frac{[CO]}{[CO_2]}} - \frac{O_{cv}}{2} \right) \times ([CO_2] + [CO]) \right\}}{\left( 1 + \frac{H_{cv}}{4} - \frac{O_{cv}}{2} \right) \times \{ ([CO_2] + [CO]) + (K_1 \times [HC]) \}}$$

where:

[ ] is the concentration in % vol, for HC only in ppm vol;

$K_1$  is the conversion factor for HC if expressed in ppm vol n-hexane (C<sub>6</sub> H<sub>14</sub>) equivalent. Its value in this formula is  $6 \times 10^{-4}$ ;

$H_{cv}$  is the atomic ratio of hydrogen to carbon in the fuel. The arbitrary value for gasoline is 1.7261;

$O_{cv}$  is the atomic ratio of oxygen to carbon in the fuel. The arbitrary value for gasoline is 0.0175;

*Note:* The simplified lambda calculation is only valid for measurements on cars with negligible NO<sub>x</sub> concentrations in the exhaust gas.

#### D.3 Other formulae

Other formulae may also be applied. As specified in 7.2.2 the operating instructions shall include the applied formula.

<sup>1</sup> As the calculation of  $\lambda$  is not compulsory, Annex D is only mandatory for those instruments capable of calculating the value of  $\lambda$ .

<sup>2</sup> J. Brettschneider, Berechnung des Luftverhältnisses  $\lambda$  von Luft-Kraftstoff-Gemischen und des Einflusses von Meßfehlern auf  $\lambda$  ("Calculation of the air ratio of air-fuel mixtures and the influence of measurement errors on  $\lambda$ ") in Bosch Technische Berichte, Volume 6 (1979), No. 4, pages 177–186.